

Future Technology Devices International Ltd.

FT4222H

USB2.0 to QuadSPI/I²C Bridge IC



FT4222H is a USB2.0 to Quad-SPI/I²C interface Device Controller with the following advanced features:

- Single chip USB2.0 Hi-speed to SPI/I²C bridge with a variety of configurations.
- Entire USB protocol handled on the chip.
- On-chip OTP memory for USB Vendor ID (VID), Product ID (PID), device serial number, product description string and various other vendor specific data.
- Configurable industry standard SPI Master/Slave interface controller.
- Support configurable data width with single, dual, quad data width transfer mode in SPI master.
- SCK can support up to 40MHz in SPI master.
- Up to 53.8Mbps data transfer rate in SPI master with quad mode transfer.
- Support single bit data transfer with full-duplex transfer in SPI Slave.
- Support up to 4 channels slave selection control pins in SPI master application.
- Configurable I²C Master/Slave interface controller conforming to I²C v2.1 and v3.0 specification.
- Support 4 speed modes as defined in the I²C-bus Specification, standard mode (SM) up to 100Kbit/s, fast mode (FM) up to 400Kbit/s, Fast mode plus (FM+) up to 1Mbit/s, and High Speed mode (HS) up to 3.4Mbit/s.
- Configurable GPIOs can be easily controlled by software applications via USB bus.
- USB Battery Charger Detection.
- USB Power Configurations; supports bus-powered, self-powered and bus-powered with power switching.
- +5V USB VBUS detection engine.
- Integrated 5V-3.3V-1.8V regulators.
- True 3.3V CMOS drive output and TTL input. (operates down to 1V8 with external pull-ups).
- Configurable I/O pin output drive strength; 4mA(min) and 16mA(max).
- Integrated power-on-reset circuit.
- USB2.0 Low operating and suspend current; 68mA (active-typ) and 375µA (suspend-typ).
- UHCI / OHCI / EHCI / XHCI host controller compatible.
- FTDI's royalty-free Direct (D2XX) drivers for Windows eliminate the requirement for USB driver development in most cases.
- Extended operating temperature range; -40°C to 85°C.
- Available in compact Pb-free 32 Pin VQFN packages (RoHS compliant).

Neither the whole nor any part of the information contained in, or the product described in this manual, may be adapted, or reproduced in any material or electronic form without the prior written consent of the copyright holder. This product and its documentation are supplied on an as-is basis and no warranty as to their suitability for any particular purpose is either made or implied. Future Technology Devices International Ltd will not accept any claim for damages howsoever arising as a result of use or failure of this product. Your statutory rights are not affected. This product or any variant of it is not intended for use in any medical appliance, device, or system in which the failure of the product might reasonably be expected to result in personal injury. This document provides preliminary information that may be subject to change without notice. No freedom to use patents or other intellectual property rights is implied by the publication of this document. Future Technology Devices International Ltd, Unit 1, 2 Seaward Place, Centurion Business Park, Glasgow, G41 1HH, United Kingdom.

1 Typical Applications

- USB to single mode SPI master controller.
- USB to dual mode SPI master controller.
- USB to quad mode SPI master controller.
- USB to single SPI slave controller.
- USB to I²C master interface controller.
- USB to I²C slave interface controller.
- Utilising USB to add system modularity.
- Incorporate USB interface to enable PC transfers for development system communication.
- USB Industrial Control.
- USB Data Acquisition.
- Accessory connectivity solutions for mobiles and tablets.
- USB dongle implementations for Software/ Hardware Encryption and Wireless Modules.
- Detect USB dedicated charging ports, to allow for high current battery charging in portable devices.

1.1 Driver Support

Royalty free D2XX Direct Drivers are available for the following Operating Systems (OS):

- Windows
- Linux
- Mac
- Android (J2xx / D2xx only)

See the following website link for the full driver support list including OS versions and legacy OS.

<https://ftdichip.com/drivers/>

D2XX Direct Drivers allow direct access to the USB device through a DLL. Application software can access the USB device through a series of DLL function calls. A support library for FT4222H, LibFT4222, must be used in conjunction with D2XX and provides high-level and convenient APIs (Application Programming Interface) to speed up user application development. For further details refer to [AN 329 User Guide for LibFT4222](#).

Example code is also provided with the LibFT4222 [download](#). Some D2xx direct functions can be used too. Refer to Appendix B – D2XX API support of [AN 329 User Guide for LibFT4222](#) and reference the [D2XX Programmer's Guide](#) document for details of those APIs which is available from the [Documents](#) section of our website.

Please also refer to the Installation Guides webpage for details on how to install the drivers.

<https://ftdichip.com/document/installation-guides/>

Please note that there is no VCP interface / drivers for FT4222H. This product can only be used with the D2xx drivers and LibFT4222 library.

1.2 Part Number

Part Number	Package	Remark
FT4222HQ-D-x	32 Pin VQFN	Rev D

Note: Packing codes for x is:

- R: Taped and Reel, 5,000pcs per reel
- T: Tray packing, 490pcs per tray

For example: FT4222HQ-D-T is 490pcs tray packing (rev D)

1.3 USB Compliant

The FT4222H is fully compliant with the USB 2.0 specification and has been given the USB-IF Test-ID (TID) 40001830.



2 FT4222H Block Diagram

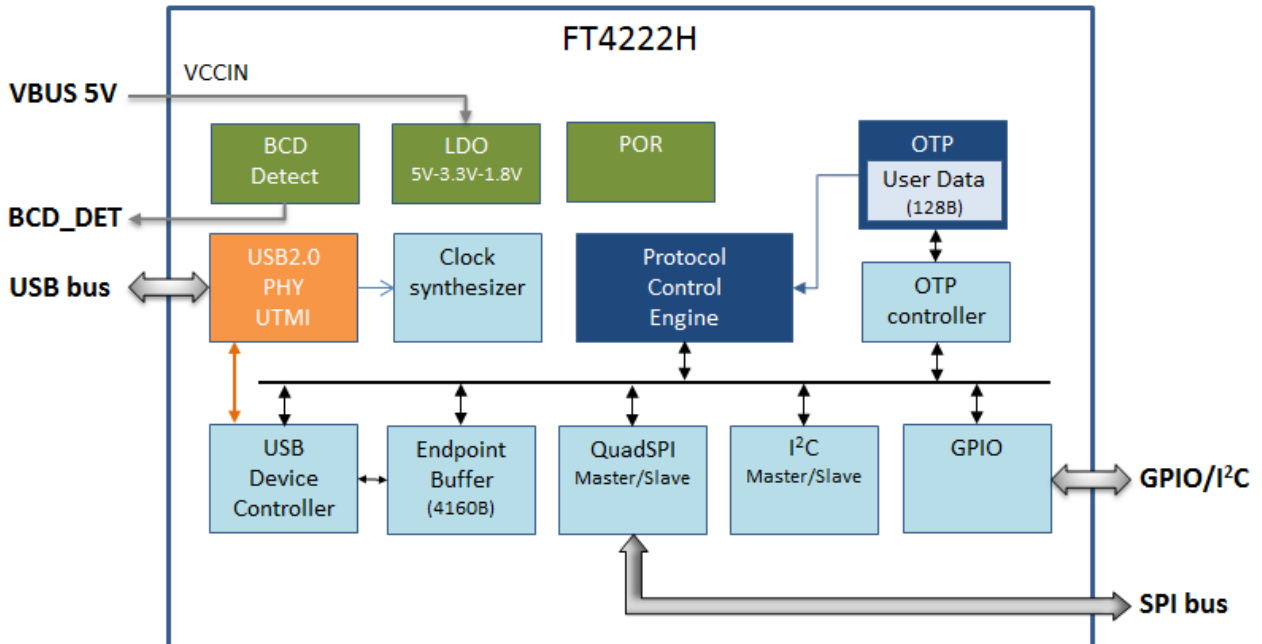

Figure 2.1 FT4222H Block Diagram

For a description of each function, please refer to Section 4.

Table of Contents

1	Typical Applications	2
1.1	Driver Support	2
1.2	Part Number	2
1.3	USB Compliant	3
2	FT4222H Block Diagram.....	4
3	Device Pin Out and Signal Description	7
3.1	VQFN-32 Package Pin Out.....	7
3.2	Pin Description.....	8
4	Function Description	10
4.1	Key Features	10
4.2	Functional Block Descriptions	11
5	FT4222H Chip Mode Configuration & SPI/I²C Interface	14
5.1	Chip Mode Configuration	14
5.2	SPI Bus Interface.....	15
5.2.1	SPI Pin Definition	15
5.2.2	SPI Bus Protocol	15
5.2.3	SCK Format	17
5.2.4	SPI Timing	18
5.3	I²C Bus Interface	20
5.3.1	I²C Pin Definition	20
5.3.2	I²C Bus Protocol.....	20
5.3.3	I²C Slave Address	21
5.3.4	I²C Timing	21
5.4	GPIOs	22
6	Devices Characteristics and Ratings	24
6.1	Absolute Maximum Ratings.....	24
6.2	ESD and Latch-up Specifications	24
6.3	DC Characteristics.....	24
6.4	OTP Memory Reliability Characteristics.....	30
7	FT4222H Configurations	31
7.1	USB Bus Powered Configuration	31
7.2	Self Powered Configuration with 5V Source Input	32

7.3	Self Powered Configuration with 3.3V Source In	33
7.4	Crystal Oscillator Configuration	34
7.5	USB Battery Charging Detection	35
8	Application Examples	36
9	Internal OTP Memory Configuration	38
9.1	Default Values	38
9.2	Method of Programming the OTP Memory	40
9.2.1	Programming the OTP memory over USB	40
10	Package Parameters	41
10.1	VQFN-32 Package Mechanical Dimensions	41
10.2	VQFN-32 Package Markings	42
10.3	Solder Reflow Profile	42
11	Contact Information	44
Appendix A – References		45
Document References		45
Acronyms and Abbreviations		45
Appendix B - List of Figures and Tables		46
List of Figures		46
List of Tables		46
Appendix C - Revision History		48

3 Device Pin Out and Signal Description

3.1 VQFN-32 Package Pin Out

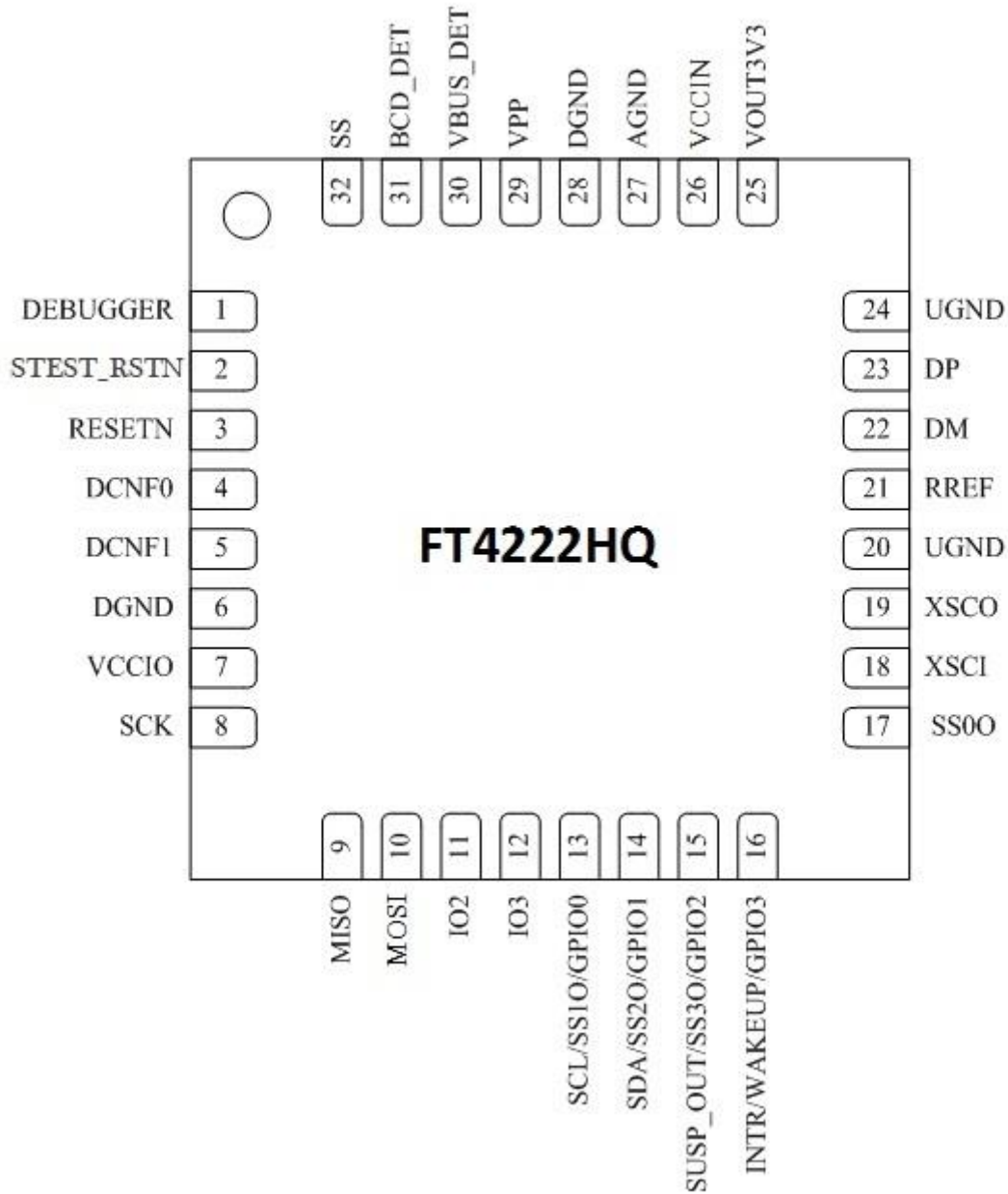

Figure 3.1 Pin Configuration VQFN-32 (Top-Down View)

3.2 Pin Description

Pin No.	Pin Name	Type	Description
1	DEBUGGER	I/O	Debugging pin. Should be reserved and tied to high.
2	STEST_RSTN	I	Chip reset input for test mode. Active low. Should be reserved and tied to high.
3	RESETN	I	Chip reset input for non-test mode operation. Active low.
4	DCNF0	I	Chip mode configuration selection bit 0. Refer to Section 5.1.
5	DCNF1	I	Chip mode configuration selection bit 1. Refer to Section 5.1.
6	DGND	P	Digital Ground.
7	VCCIO	** P	+3.3V/2.5V/1.8V supply voltage. This is the supply voltage for all the I/O ports. This pin shall be connected to pin 25 when I/O ports are working at 3.3V.
8	SCK	I/O	SPI interface clock. Serial clock output for SPI master; serial clock input for SPI slave mode.
9	MISO	I/O	In SPI master single mode, it is master serial data input. In SPI master dual/quad mode, it is SPI data bus bit 1. In SPI slave mode, it is slave serial data output.
10	MOSI	I/O	In SPI master single mode, it is master serial data output. In SPI master dual/quad mode, it is SPI data bus bit 0. In SPI slave mode, it is slave serial data input.
11	IO2	I/O	Quad SPI data bus bit 2.
12	IO3	I/O	Quad SPI data bus bit 3.
13	GPIO0/SS10/SCL	I/O	GPIO 0 (default) can be configured as slave selection 1, output pin for SPI master mode or serial clock for I ² C mode.
14	GPIO1/SS20/SDA	I/O	GPIO 1 (default) can be configured as slave selection 2, output pin for SPI master mode or serial data for I ² C mode.
15	GPIO2/SS30/SUSP_0 UT	I/O	GPIO 2 (default) can be configured as slave selection 3, output pin for SPI master mode or USB suspend output indicator.
16	GPIO3/WAKEUP/INTR	I/O	GPIO 3 (default) and can be configured as USB remote wakeup input pin or interrupt input.
17	SS00	O	Slave selection 0, output pin for SPI master mode.
18	XSCI	AI	Crystal oscillator input, 12MHz only. Related application circuit can be referred to in Section 7.4.
19	XSCO	AO	Crystal oscillator output, 12MHz only. Related application circuit can be referred to in Section 7.4.
20	UGND	P	USB Analog Ground.
21	RREF	AI	USB peripheral reference voltage input. Connect 12kΩ +/- 1% resistor to GND.
22	DM	AI/O	USB peripheral bidirectional DM line.
23	DP	AI/O	USB peripheral bidirectional DP line.
24	UGND	P	USB Analog Ground.
25	VOUT3V3	** P	+3.3V voltage Out May be used to power VCCIO. When VCCIN is supplied with 3.3V, this pin is a power input pin. Connect to pin 26.
26	VCCIN	** P	+5.0V(or 3.3V) supply voltage In Power source-in to embedded regulator.
27	AGND	P	Analog Ground.
28	DGND	P	Digital Ground.
29	VPP	P	+6.5V supply voltage In.

Pin No.	Pin Name	Type	Description
			Power source for Programming embedded OTP. It should be kept floating or 0V when not in programming mode.
30	VBUS_DET	I	VBUS detection input. It is a +5.0V tolerant pin.
31	BCD_DET	O	Battery charger detection indicator output when the device is connected to a dedicated battery charger port. Polarity can be defined.
32	SS	I	SPI slave selection indicator from SPI master. This pin is active in SPI slave mode. It must be tied to high when SPI master mode enabled.

Table 3.1 FT4222H Pin Description

**If VCCIN is supplied with 3.3V power input, then VOUT3V3 and VCCIO must also be driven with this 3.3V power source.

4 Function Description

The FT4222H is a Hi-Speed USB2.0-to-Quad SPI/ I²C device controller in a compact 32-pin VQFN package. The FT4222H requires an external Crystal (12 MHz) for the internal PLL to operate. It supports multi-voltage IO, 3.3V, 2.5V or 1.8V. It also provides 128 bytes one-time-programmable (OTP) memory space for storing vendor specific information.

The FT4222H contains SPI/ I²C configurable interfaces. The SPI interface can be configured in master mode with single, dual, or quad bits data width transfer or in slave mode with single bit data width transfer. The I²C interface can be configured in master or slave mode.

4.1 Key Features

Functional Integration. The FT4222H is a USB 2.0 Hi-Speed (480Mbps/s) to flexible and configurable SPI or I²C interfaces IC. The FT4222H includes an integrated +1.8V and +3.3V Low Drop-Out (LDO) regulator and 12MHz to 480MHz PLL. It also includes Power-On-Reset (POR), VBUS detection with 5V-tolerance and 128 bytes one-time-programmable (OTP) memory which simplify external circuit design and reduce external component count.

USB2.0 Hi-Speed Device Controller. The FT4222H integrates a USB protocol engine which controls the physical Universal Transceiver Macrocell Interface (UTMI) and handles all aspects of the USB 2.0 Hi-Speed interface. It contains one control endpoint, and 4-pairs of IN and OUT endpoints. These endpoints can implement up to 4 independent interfaces/applications mapped to combined I²C, GPIO, SPI interfaces.

Highly Integrated USB2.0 to Configurable SPI Bridge. The FT4222H provides the bridge function between a USB2.0 device, upstream port and an SPI Master/Slave.

A support library, LibFT4222, based on FTDI's D2XX driver, enables easy configuration of the SPI as a master or slave. Operating clock frequency on the SPI bus, clock phase and polarity, transfer data bit width mode, and the number of slave selection controls are also configurable.

The maximum SPI interface operating clock can be set up to 40MHz in master mode and 20MHz in slave mode. With quad mode (4-bits) data bus width, the max data transfer throughput can be up to 53.8Mbps.

USB to Configurable I²C Controller. The FT4222H also provides the bridge function between a USB2.0 device upstream port and an I²C Master/Slave interface.

A support library, LibFT4222, based on FTDI's D2XX driver, enables easy configuration of the I²C as either a master or slave, including target operating speed and bus protocol on the I²C bus.

The device can run at common I²C bus speeds, standard mode (SM), fast mode (FM), Fast mode plus (FM+), and High Speed mode (HS). A higher bit rate on the I²C bus is also configurable up to 3.4Mbit/s. Clock stretching is supported to conform to v2.1 and v3.0 of the I²C specification.

Configurable GPIOs. There are 4 GPIO pins in the FT4222H that can be configured for different purposes, such as a suspend indicator output, remote wake up input, an interrupt input or general purpose Input/Output. These GPIOs can be easily initialized and fully controlled at the USB host side by the application programming interface (API) defined in LibFT4222.

Signal drive strength and slew rate of these GPIOs can be configured via the FT_Prog utility for different design needs.

Embedded OTP memory. The internal OTP memory in the FT4222H is used to store USB Vendor ID (VID), Product ID (PID), device serial number, product description string and various other USB configuration descriptors. With this embedded OTP memory, the device can store vendor specific information and save the cost on BOM. The descriptors can be programmed using the FTDI utility software called FT_PROG, which can be downloaded from the FTDI Utilities page on the FTDI website (https://ftdichip.com/utilities/#ft_prog).

Power management. USB 2.0 suspend/resume and remote wakeup are fully supported. The PHY will be put to a power saving mode and the clock to most of the digital circuits will be stopped when the device is suspended.

Source Power and Power Consumption. The FT4222H is capable of operating at a voltage supply of +3.3V or +5.0V with a nominal operational mode current of 68mA and a nominal USB suspend mode current of 375µA. This allows greater margin for peripheral designs to meet the USB suspend mode current limit of 2.5mA. An integrated level converter within the FT4222H allows the device to interface with logic running at +1.8V, +2.5V or +3.3V. (Note: External pull-ups are recommended for IO <3V3).

4.2 Functional Block Descriptions

The following paragraphs detail each function within the FT4222H. Please refer to the block diagram shown in Figure 2.1.

USB2.0 UTMI PHY. The Universal Transceiver Macrocell Interface (UTMI) is a physical interface cell. This block handles the full speed and high speed SERDES (serialise – de-serialise) function for the USB TX/RX data. It also provides the clocks for the rest of the chip. A 12MHz crystal should be connected to the XSCI and XSCO pins. A 12kΩ resistor should be connected between REF and GND on the PCB.

The UTMI PHY functions include:

- Supports 480 Mbit/s "Hi-Speed" (HS) and 12 Mbit/s "Full Speed" (FS)
- SYNC/EOP generation and checking
- Data and clock recovery from a serial stream on the USB
- Bit-stuffing/unstuffing; bit stuff error detection
- Manages USB Resume, Wake Up and Suspend functions

Single parallel data clock output with on-chip PLL to generate higher speed serial data clocks.

USB Device Controller. The USB Device controller in the FT4222H controls and manages the interface between the UTMI PHY and the interfaces of the chip. It provides 9 endpoints to fit into the FT4222H applications.

The USB Device Controller function includes:

- Endpoint-0 for a control pipe with max packet size 64 Bytes
- 4 endpoints for bulk-in pipe with configurable max packet size up to 512 Bytes
- 4 endpoints for bulk-out pipe with configurable max packet size up to 512 Bytes
- Multiple interfaces configuration support
- Suspend detection and power management
- Remote wake-up support
- Fully compatible to USB2.0 specification requirement

Endpoint Buffer. For fulfilling the max packet size requirement and high performance data transfer throughput, the Endpoint Buffer is 4160 bytes SRAM with configurable size management to each endpoint. It can be configured as single or double buffers and adjustable size for each endpoint.

QuadSPI Master/Slave Controller. The QuadSPI is a fully configurable SPI master/slave device, which allows the user to configure polarity and phase of the serial clock signal SCK. When SPI is configured as a master, it can be configured automatically to drive slave select outputs (SS30 – SS00), and address the SPI slave device to exchange serially shifted data. The data bus can be configured as single (1bit), dual (2-bits) and quad (4-bits) mode for different transfer requests and applications. The interface operating clock can be easily configured up to 40MHz. When SPI is configured as a slave, the SPI engine can support one slave port and operate a single data mode transfer. The max acceptable operating clock can be up to 20MHz. The QuadSPI controller can be configured via a support library, LibFT4222. For details refer to the [AN_329 User Guide for LibFT4222](#).

QuadSPI as master functions include:

- Single Mode (1-bit) data transfer with full duplex serial data transfer
- Dual Mode (2-bit) data transfer
- Quad Mode (4-bit) data transfer
- Up to 4 SPI slave channels can be addressed via pins SS30~SS00
- Shared data bus to minimize related pin counts
- 4 types of transfer format can be selected by Phase and Polarity
- Configurable interface clock on SCK as 1/2, 1/4, 1/8, 1/16, 1/32, 1/64, 1/128, 1/256, 1/512 of 80MHz, 60MHz, 48MHz and 24MHz

SCK Freq. (Hz)		SCK = Operating Clock * the following ratio								
Operating Clock	Max Throughput can be expected	1/2	1/4	1/8	1/16	1/32	1/64	1/128	1/256	1/512
80MHz	52.8Mbps*	40M*	20M*	10M	5M	2.5M	1.25M	625K	312.5K	156.25K
60MHz	39.7Mbps*	30M*	15M	7.5M	3.75M	1.875M	937.5K	468.75K	234.375K	117,18K
48MHz	31.5Mbps*	24M*	12M	6M	3M	1.5M	750K	375K	187.5K	93.75K
24MHz	15.8Mbps*	12M*	6M	3M	1.5M	750K	375K	187.5K	93.75K	46.875K

Table 4.1 SCK Operating Frequency in SPI Master Mode

*The max. throughput can be expected under the condition of quad mode transfers on FT4222H with a high operating frequency on SCK. It also depends on the USB bus transfer condition. For example, the max throughput that can be expected is up to 52.8Mbps when the operating clock is equal to 80MHz, SCK is set as 40MHz, only 1 data stream interface is enabled not 3 or 4, the data bus is operating in quad mode and the USB bus is operating at hi-speed USB rates with sufficient bandwidth.

QuadSPI as slave functions include:

- Single Mode (1-bit) data transfer with full duplex serial data transfer
- Can accept SCK operating frequency up to 20MHz

Operating Clock Frequency	Max Acceptable Frequency on SCK
80MHz	<= 20MHz
60MHz	<= 15MHz
48MHz	<= 12MHz
24MHz	<= 6MHz

Table 4.2 Max. Acceptable Operating Frequency on SCK in SPI Slave Mode

I²C Master/Slave Controller. I²C (Inter Integrated Circuit) is a multi-master serial bus invented by Philips. I²C uses two bi-directional open-drain wires called serial data (SDA) and serial clock (SCL). Common I²C bus speeds are the standard mode (SM) with bit rate up to 100Kbit/s, fast mode (FM) with the bit rate up to 400Kbit/s, Fast mode plus (FM+) with the bit rate up to 1Mbit/s, and High Speed mode (HS) with the bit rate up to 3.4Mbit/s. Refer to the I²C specification for more information on the protocol.

The FT4222H device can operate as master or slave, and the major functions include:

- Master or slave mode configurable
- Fully compatible to v2.1 and v3 specification
- 7-bit address support
- Support 4 speed configurations defined in I²C-bus specification
- Support bit rate up to 3.4Mbit/s both in master and slave mode
- Clock stretching support in master and slave mode

GPIOs. FT4222H contains 4 GPIO pins for various functions. The drive strength, slew rate control and pull high/low resistors can be configured in the vendor configurable area of the OTP via FT_PROG. When the USB GPIO interface is enabled and supported, GPIOs can be directly controlled by APIs (Application Programming Interface) which are defined in the support library, LibFT4222, to match the requirement.

GPIOs in the FT4222H functions include:

- GPIO0 can be configured as GPIO0 or I²C SCL or SPIM slave selection SS10
- GPIO1 can be configured as GPIO1 or I²C SDA or SPIM slave selection SS20

- GPIO2 can be configured as GPIO2 or USB suspend status output(SUSP) or SPIM slave selection SS30
- GPIO3 can be configured as GPIO3 or USB remote wake-up input(WAKE) or external interrupt input(INTR)
- Adjustable Driving Strength : 4mA/8mA/12mA/16mA
- Slew Rate, Pull High/Low resistor, open drain configurable
- WAKE can be configured as rising or falling edge triggered
- SUSP trigger mode can be configured as rising edge, falling edge, high level and low level trigger

For configuration details refer to section 9.1.

Built-in Clock Synthesizer. With an on-chip clock synthesizer, the FT4222H may operate with a low-cost 12 MHz crystal (or oscillator) by connecting to XSCI and XSCO, and generates a standard internal 480 MHz clock for the USB interface. The Clock Synthesizer takes the 480MHz clock from the embedded UTMI PHY and generates the 80MHz, 60MHz, 48MHz and 24MHz as reference clocks. The user can select one of these reference clocks via the API, FT4222_SetClock which is defined in LibFT4222, as the system operating clock. The system operating clock will be the base and used by the embedded functions to generate the required interface clock.

Protocol Control Engine. The FT4222H has an embedded and robust control engine. It deals with the USB enumeration commands and flow control between driver and function such as SPI or I²C devices. It can perform the bridge function initialization and enable an exceptional data transfer performance through the USB bus. It collects and summarizes the SPI and I²C bus protocol and simplifies the protocol as a command set via the USB Bulk transfer pipe. A support library, LibFT4222, is defined for the FT4222H and is responsible for communicating with this protocol engine. With related APIs (Application Programming Interface) defined in LibFT4222, this control engine provides a very flexible USB bridge for SPI and I²C bus access suitable for a wide range of applications.

OTP Controller + Internal OTP Memory. The internal OTP memory provides storage for vendor configuration data. This vendor configuration area, named as user area, is used to store USB Vendor ID (VID), Product ID (PID), device serial number, product description string and various other USB configuration descriptors. It is also used to configure the function pins capability. For further details refer to Section 9. This user area in the internal OTP memory is available to system designers to allow storing additional data from the user application over USB. The internal OTP memory can be programmed in circuit, over USB with an external voltage requirement on the VPP pin (6.5V). The descriptors can be programmed using the FTDI utility software called FT_PROG, which can be downloaded from FTDI Utilities on the FTDI website (https://ftdichip.com/utilities/#ft_prog).

5V-3.3V-1.8V LDO regulator. The LDO will regulate out 2 reference voltages for use within the FT4222H. The +3.3V LDO regulator generates the +3.3V reference voltage for driving the USB transceiver cell output buffers. It requires an external decoupling capacitor to be attached to the VOUT3V3 regulator output pin. Another +1.8V LDO regulator generates the +1.8V reference voltage for driving the internal core of the IC.

POR RESET Generator. POR is the integrated Power on Reset Generator Cell providing a reliable power-on reset to the device internal circuitry at power up. There is also a RESETN input pin allowing an external device to reset the FT4222H. RESETN can be tied to VCCIO (+3.3V) if not being used.

Embedded BCD Detection. Supports Battery Charger Detection. The BCD_DET pin will be active if the device is connected to a dedicated charger instead of a standard USB Host. Refer to section 7.5 for an example application circuit.

5 FT4222H Chip Mode Configuration & SPI/I²C Interface

5.1 Chip Mode Configuration

The FT4222H has 4 configuration modes selected by {DCNF1, DCNF0}. The chip configuration mode will determine the number of USB interfaces for data streams and for GPIO control. The data stream interface is for data transfer between the USB2.0 host and the SPI/ I²C device. The purpose of the GPIO interface is for fully controlling the GPIOs. The following table shows the pin functions corresponding to the chip configuration mode.

Pin Functions	CNFMODE0 {DCNF1, DCNF0} = 00	CNFMODE1 {DCNF1, DCNF0} = 01	CNFMODE2 {DCNF1, DCNF0} = 10	CNFMODE3 {DCNF1, DCNF0} = 11
USB interface number	1 for data stream 1 for GPIOs	3 for data stream 1 for GPIOs	4 for data stream	1 for data stream
SPI Master(SPIM) related pins (SCK, MISO, MOSI, IO2, IO3, SS00)	SPIM*	Active USB interface-0	Active USB interface-0	SPIM*
SPI Slave(SPIS) related pins (SCK, MISO, MOSI, SS)	SPIS*	Disable	Disable	SPIS*
GPIO0	GPIO/SCL*	SS10 USB interface-1	SS10 USB interface-1	SCL*
GPIO1	GPIO/SDA*	SS20 USB interface-2	SS20 USB interface-2	SDA*
GPIO2	GPIO/SUSP	GPIO/SUSP	SS30 USB interface-3	SUSP
GPIO3	GPIO/WAKE/INTR	GPIO/WAKE/INTR	WAKE	WAKE

Table 5.1 FT4222H Pin Functions on Chip Configuration Mode

*One of the SPIM, SPIS, I²C function is selected, the other 2 functions will be disabled.

Note that GPIOx pins cannot be controlled by the software driver when GPIOx pins play the role as SPIM SSxO, I²C SCL/SDA, SUSP or WAKE.

Chip Configuration only determines the number of interface/functions supported but do not decide which bus interface (SPI/ I²C /GPIO) or which role (master/slave) that the FT4222H will take. The user can use the initialisation APIs provided by the support library, LibFT4222, to configure which interface and role will be taken.

The support library for FT4222H, LibFT4222, which is based on D2XX, provides high-level and convenient APIs (Application Programming Interface) to speed up user application development. For further details refer to the [AN_329 User Guide for LibFT4222](#).

5.2 SPI Bus Interface

5.2.1 SPI Pin Definition

The QuadSPI function in the FT4222H is a fully configurable SPI master/slave device. Users can utilize the API in LibFT4222, FT4222_SPIMaster_Init or FT4222_SPISlave_Init, to select in which mode (master or slave) the FT4222H will function. When the FT4222H is set as a USB-to-SPI bridge function, and chip configuration mode is chosen, the pins of the FT4222H will be mapped accordingly. The SPI related pins are

- Clock – SCK (pin-8), 4 types of transfer formats supported, details refer to Section 5.2.2
- Data – MISO (pin-9), data transfer from slave to master for single mode, or data bus bit-1 for dual and quad mode
 - MOSI (pin-10), data transfer from master to slave for single mode, or data bus bit-0 for dual and quad mode
 - IO2 (pin-11), data bus bit-2 for quad mode
 - IO3 (pin-12), data bus bit-3 for quad mode
- Slave Selection when QuadSPI acts as SPI master
 - SS00 (pin-17), slave selection to slave device-0
 - SS10 (pin-13), slave selection to slave device-1
 - SS20 (pin-14), slave selection to slave device-2
 - SS30 (pin-15), slave selection to slave device-3
- Slave Selection when QuadSPI acts as SPI slave
 - SS (pin-32), slave selection for SPI master control. Must tie high when QuadSPI acts as SPI master

5.2.2 SPI Bus Protocol

The QuadSPI allows SPI data transfers in three types of bit width:

- Single SPI transfer – Standard data transfer format – data is read and written simultaneously
- DUAL SPI Transfer/Receive - Data is transferred out or received in on 2 SPI lines simultaneously
- QUAD SPI Transfer/Receive – Data is transferred out or received in on 4 SPI lines simultaneously

The operating bit width in single, dual or quad mode can also be determined by these 2 APIs, FT4222_SPIMaster_Init and FT4222_SPISlave_Init, which are defined in LibFT4222 when the SPI function is enabled and selected.

When the FT4222H is operating as an SPI master or slave device, QuadSPI can transfer data in single bit mode with full-duplex transmission. Figure 5.1 shows the basic protocol in single transfer mode.

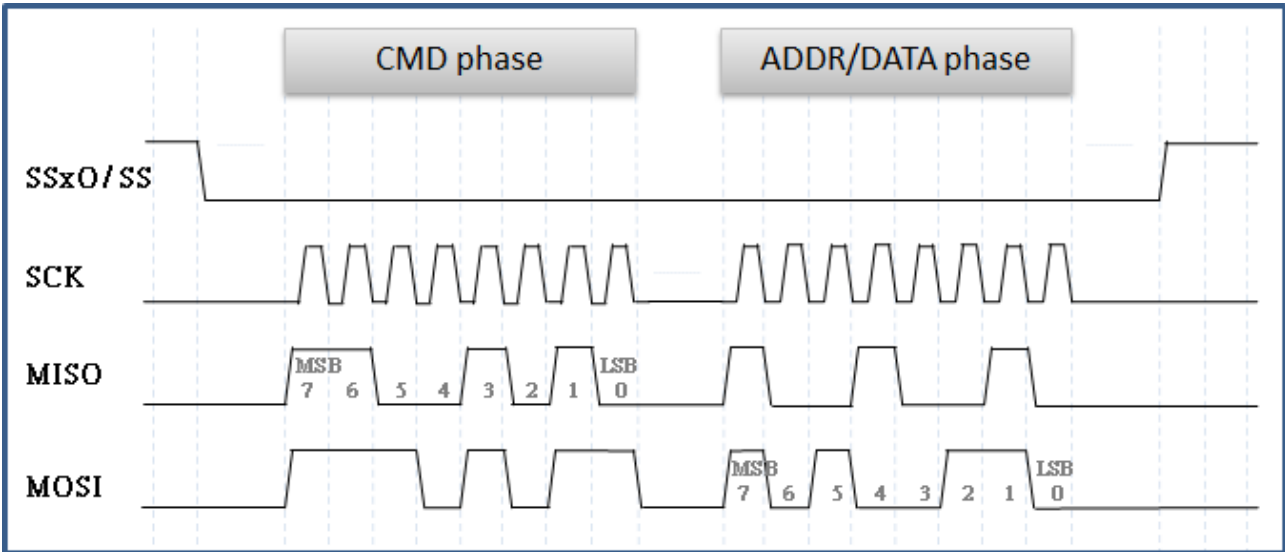

Figure 5.1 QuadSPI Bus Protocol when Transferring in Single Mode

QuadSPI can operate in dual or quad transfer mode when QuadSPI is programmed as an SPI master. These multi-bit transfer modes can speed up the data transfer rate between QuadSPI and the SPI slave device supporting the multi-bit transfer. Figure 5.2 shows the bus protocol in dual or quad mode.

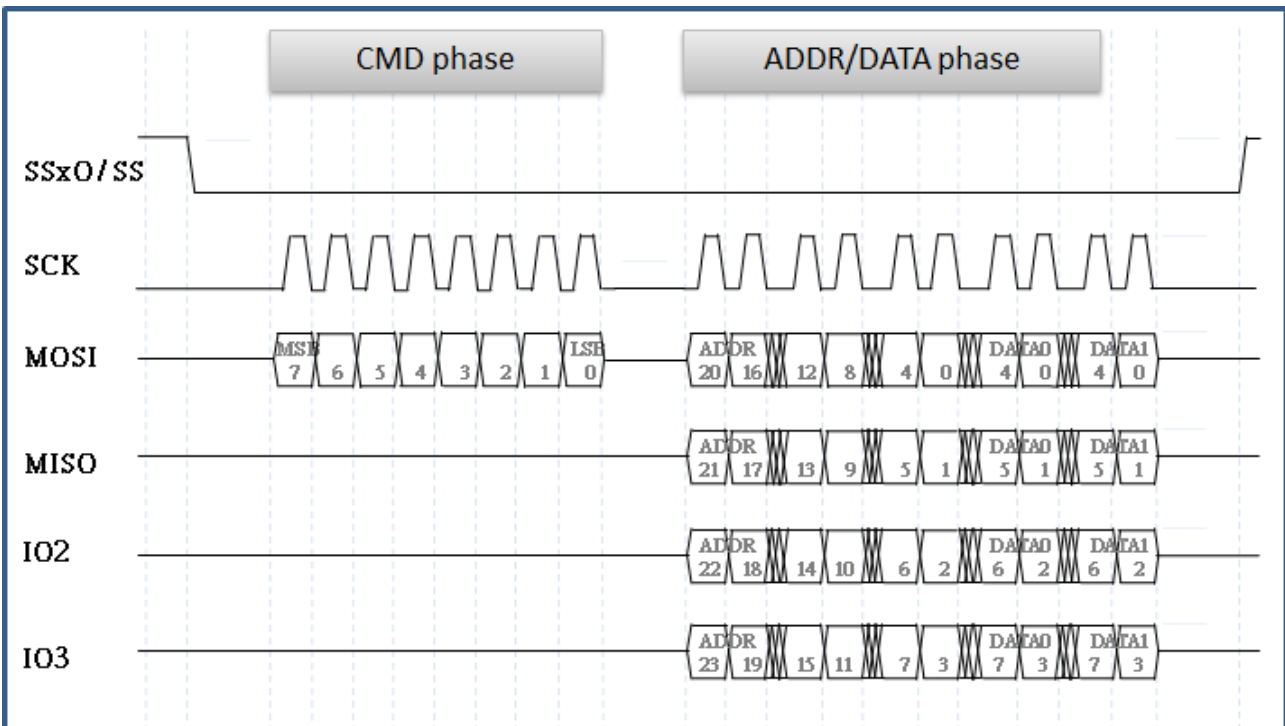

Figure 5.2 QuadSPI Bus Protocol when Transferring in Quad Mode

5.2.3 SCK Format

Software can select any of four combinations of serial clock (SCK) phase and polarity. The clock polarity is specified by the CPOL control bit, which selects an active high or active low clock and has no significant effect on the transfer format. The clock phase (CPHA) control bit selects one of two fundamentally different transfer formats. The clock phase and polarity should be identical for the master SPI device and the communicating slave device. In some cases, the phase and polarity are changed between transfers to allow a master device to communicate with peripheral slaves having different requirements. The flexibility of the SPI system on the QuadSPI allows direct interface to almost any existing synchronous serial peripheral. Users can also use the FT4222_SPIMaster_Init API which is defined in the support library LibFT4222 to select the operating phase and polarity of SCK.

5.2.3.1 CPHA=0 Transfer Format

Figure 5.3 shows a timing diagram of an SPI transfer where CPHA is equal to 0. Two waveforms are shown for SCK: one for CPOL equal to 0 and another for CPOL equal to 1. The diagram may be interpreted as a master or slave timing diagram since the SCK, master in/slave out (MISO), and master out/slave in (MOSI) pins are directly connected between the master and the slave. The MISO signal is the output from the slave, and the MOSI signal is the output from the master.

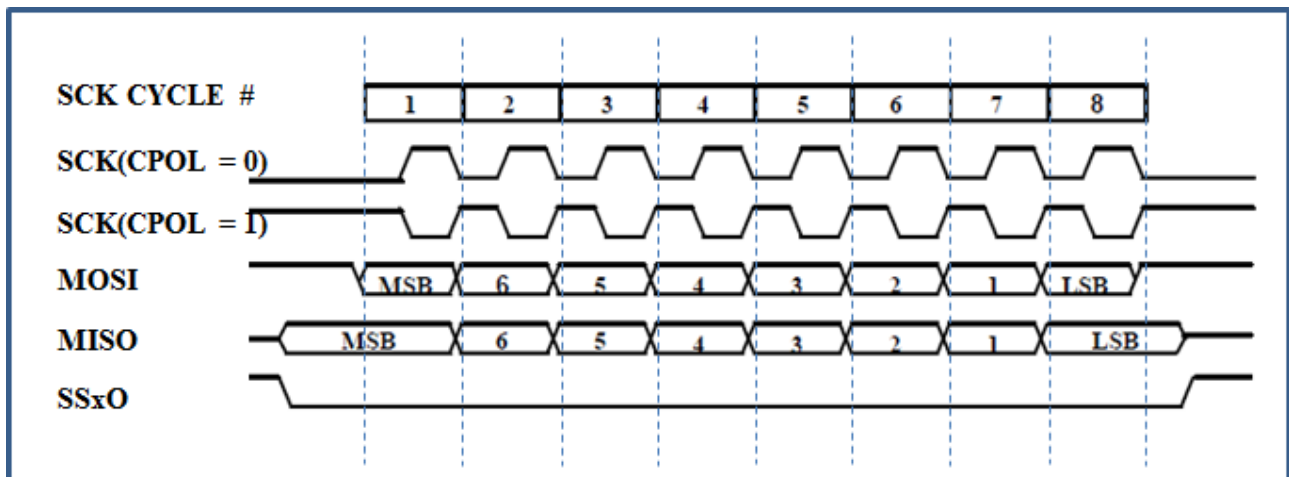

Figure 5.3 SCK Transfer Format when CPHA=0

5.2.3.2 CPHA=1 Transfer Format

Figure 5.4 is a timing diagram of an SPI transfer where CPHA equal to 1. Two waveforms are shown for SCK: one for CPOL equal to 0 and another for CPOL equal to 1. The diagram may be interpreted as a master or slave timing diagram since the SCK, MISO, and MOSI pins are directly connected between the master and the slave. The MISO signal is the output from the slave, and the MOSI signal is the output from the master. The SS line is the slave select input to the slave.

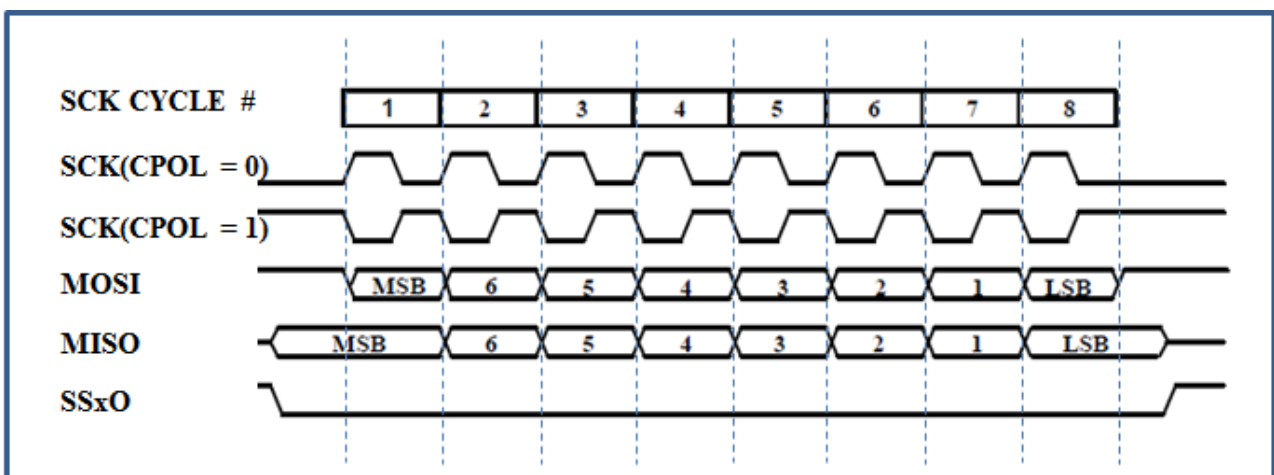

Figure 5.4 SCK Transfer Format when CPHA=1

5.2.4 SPI Timing

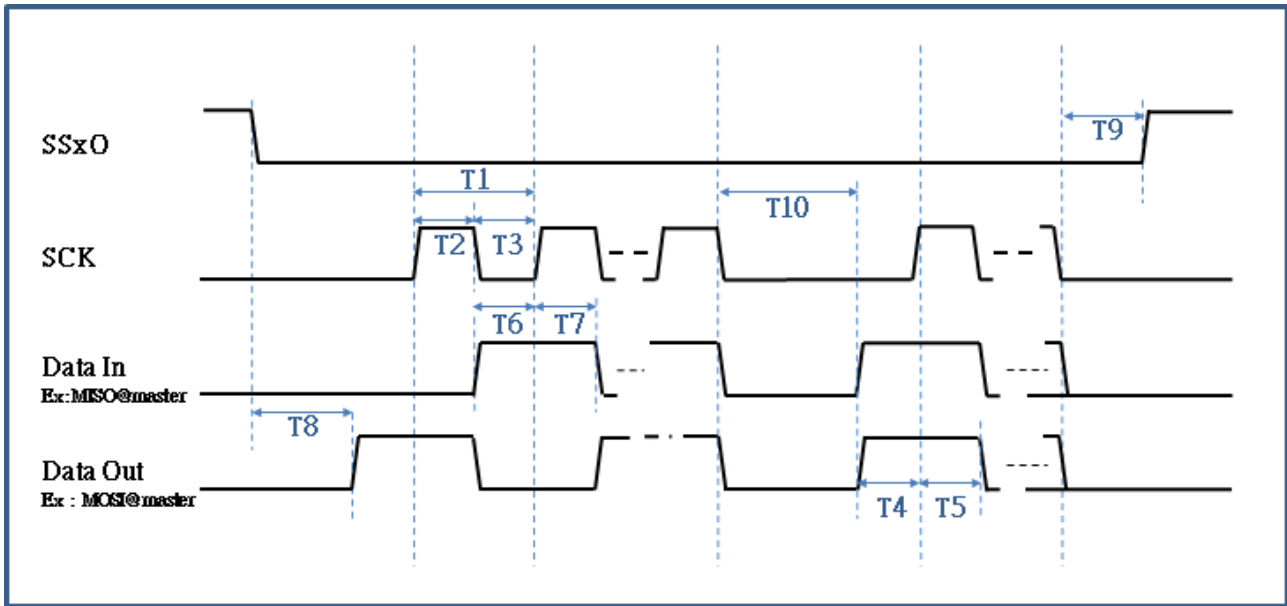

Figure 5.5 SPI Timing

Table 5.2 shows the timing information for QuadSPI. The result is under the condition of all the related pins with 5pF loading. T6 is the required setup time to the related SCK edge for the input data path of QuadSPI. The minimum value of T4 means that the guaranteed setup time to the related SCK edge for connected device to fetch data from QuadSPI. The maximum value of T6 means that data can be accepted correctly by QuadSPI with 5pF pin loading assumed. If the pin load is larger, the timing should be considered conservatively.

Parameter	Min (ns)	Typ(ns)	Max(ns)	Description
T0@48MHz		20.833		T0 is the period when operating clock=48MHz
T0@60MHz		16.666		T0 is the period when operating clock=60MHz
T0@80MHz		12.500		T0 is the period when operating clock=80MHz
Timing for SPI				
T1@master	T2+T3			SCK Period when QuadSPI as master
T1@slave	50			Acceptable SCK Period when QuadSPI as slave device
T2	T0	2 ⁿ * T0	256*T0	SCK HIGH, related to the operating clock and ratio n = 0, 1, 2, ..., 8
T3	T0	2 ⁿ * T0	256*T0	SCLK LOW, related to the operating clock and ratio n is the same definition as in T2
T4	T3-2.0		T3-1.1	Data output path: setup time to corresponding SCK edge
T5	T2+0.1		T2+0.6	Data output path: hold time to corresponding SCK edge
T6	9.8			Data input path: required setup time to corresponding SCK edge
T7			0.1	Data input path: required hold time to corresponding SCK edge
T8	25*T0			SSxO setup time to 1 st SCK period boundary
T9	880*T0			SSxO hold time from last SCK period boundary
T10@master		6*T0		Idle time on SCK between byte boundary when master
T10@slave	0			Idle time on SCK between byte boundary when slave

Table 5.2 SPI Timing for VCCIO=3.3V with 5pF output pin load

Table 5.3 shows the timing information for QuadSPI with VCCIO equal to 1.8V and with 5pF loading on all the related pins. The required setup time for input path is increasing since VCCIO=1.8V. The maximum operating frequency of SCK is recommended not exceeded 40MHz.

Parameter	Min (ns)	Typ(ns)	Max(ns)	Description
T0@48MHz		20.833		T0 is the period when operating clock=48MHz
T0@60MHz		16.666		T0 is the period when operating clock=60MHz
T0@80MHz		12.500		T0 is the period when operating clock=80MHz
Timing for SPI				
T1@master	T2+T3			SCK Period when QuadSPI as master
T1@slave	50			Acceptable SCK Period when QuadSPI as slave device
T2	T0	2 ⁿ * T0	256*T0	SCK HIGH, related to the operating clock and ratio n = 0, 1, 2, ..., 8
T3	T0	2 ⁿ * T0	256*T0	SCLK LOW, related to the operating clock and ratio n is the same definition as in T2
T4	T3-2.1		T3-1.2	Data output path: setup time to corresponding SCK edge
T5	T2+0.1		T2+0.6	Data output path: hold time to corresponding SCK edge
T6	8.6		16.5	Data input path: required setup time to corresponding SCK edge
T7			0.1	Data input path: required hold time to corresponding SCK edge
T8	25*T0			SSxO setup time to 1 st SCK period boundary
T9	880*T0			SSxO hold time from last SCK period boundary
T10@master		6*T0		Idle time on SCK between byte boundary when master
T10@slave	0			Idle time on SCK between byte boundary when slave

Table 5.3 SPI Timing for VCCIO=1.8V with 5pF output pin load

5.3 I²C Bus Interface

I²C (Inter Integrated Circuit) is a multi-master serial bus invented by Philips. I²C uses two bi-directional open-drain wires called serial data (SDA) and serial clock (SCL). Common I²C bus speeds are standard mode (SM) with bit rate up to 100Kbit/s, fast mode (FM) with bit rate up to 400Kbit/s, Fast mode plus (FM+) with bit rate up to 1Mbit/s, and High Speed mode (HS) with the bit rate up to 3.4Mbit/s.

An I²C bus node can operate either as a master or a slave:

- Master node – issues the clock and addresses slaves
- Slave node – receives the clock line and address.

The FT4222H can operate as a master or slave, and is capable of being set to the speed modes defined in the I²C bus specification. Besides the speed mode defined in the I²C standard specification, the I²C controller of the FT4222H can support flexible SCL frequencies defined by the following function.

$$SCL\ Freq = \frac{\text{Operating Clock Frequency}}{M \times (N+1)} \quad M = 6\ \text{or}\ 8; \quad N = 1, 2, 3, \dots, 127$$

When the target frequency is below 100KHz, M will be equal to 8; otherwise, M will be equal to 6. For example, to generate a 2.5MHz frequency on SCL, M will be selected as 6. Then with an operating clock frequency equal to 60MHz the user can set N as 3. The SCL frequency for I²C master mode can be set via the FT4222_I2CMaster_Init command defined in the support library, LibFT4222. Refer to the [AN 329 User Guide for LibFT4222](#) for further details.

5.3.1 I²C Pin Definition

The I²C function in the FT4222H is a fully configurable I²C master/slave device. When the chip configuration is set as CNFMODE0 or CNFMODE3 and the USB-to-I²C bridge function is enabled via the FT4222_I2CMaster_Init API which is defined in the support library LibFT4222. The pins of the FT4222H will be mapped accordingly. The I²C pins are

- Clock – SCL (pin-13), as clock output with open-drain design when I²C bus is set as master.
as clock input when I²C bus is set as slave.
- Data – SDA (pin-14), command/address/data transfer between master and slave with open-drain design.

5.3.2 I²C Bus Protocol

There are four potential modes of operation for a given bus device, although most devices only use a single role (Master or Slave) and its two modes (Transmit and Receive):

- Master transmit – sending data to a slave
- Master receive – receiving data from a slave
- Slave transmit – sending data to a master
- Slave receive – receiving data from the master

The following figure shows the basic I²C bus protocol:

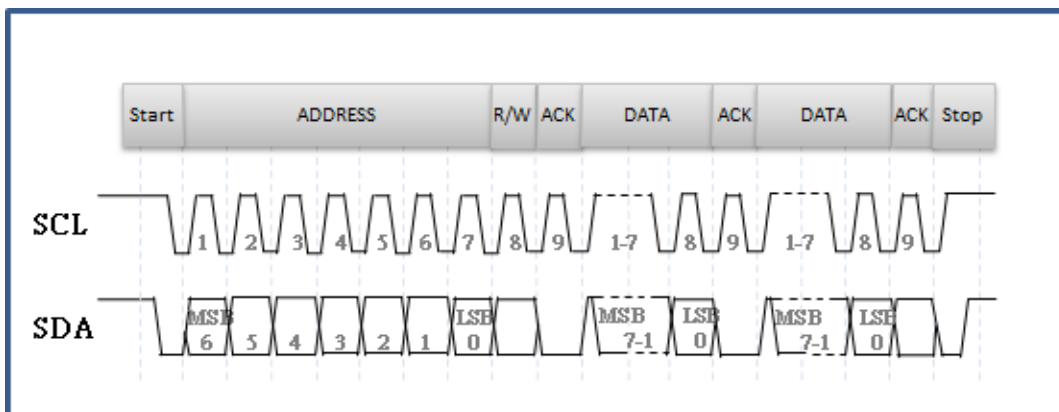

Figure 5.6 I²C Bus Protocol

The master is initially in master transmit mode by sending a start bit followed by the 7-bit address of the slave it wishes to communicate with, which is finally followed by a single bit representing whether it wishes to write(0) to or read(1) from the slave.

If the slave exists on the bus then it will respond with an ACK bit (active low for acknowledged) for that address. The master then continues in either transmit or receive mode (according to the read/write bit it sent), and the slave continues in its complementary mode (receive or transmit, respectively).

The address and the data bytes are sent most significant bit first. The start bit is indicated by a high-to-low transition of SDA with SCL high; the stop bit is indicated by a low-to-high transition of SDA with SCL high.

If the master wishes to write to the slave then it repeatedly sends a byte with the slave sending an ACK bit. (In this situation, the master is in master transmit mode and the slave is in slave receive mode.)

If the master wish to read from the slave then it repeatedly receives a byte from the slave, the master sends an ACK bit after every byte but the last one. (In this situation, the master is in master receive mode and the slave is in slave transmit mode.)

The master then ends transmission with a stop bit, or it may send another START bit if it wishes to retain control of the bus for another transfer (a "combined message").

I²C defines three basic types of message, each of which begins with a START and ends with a STOP:

- Single message where a master writes data to a slave;
- Single message where a master reads data from a slave;
- Combined messages, where a master issues at least two reads and/or writes to one or more slaves

In a combined message, each read or write begins with a START and the slave address. After the first START, these are also called repeated START bits; repeated START bits are not preceded by STOP bits, which is how slaves know the next transfer is part of the same message.

Users can refer to the I²C specification for more information on the protocol.

5.3.3 I²C Slave Address

When the FT4222H is configured as a USB to I²C master bridge, it must be able to issue any value of 7-bits slave address. Users can issue I²C commands to read or write data to a slave via the commands FT4222_I2CMaster_Read and FT4222_I2CMaster_Write, defined in the support library LibFT4222, with a corresponding slave address.

When the FT4222H is configured as a USB to I²C Slave Bridge, the slave address may be defined by the user. This slave address parameter is defined by default as 40h and can be set once in the I²C Slave Address parameter which is defined in the user data area of the OTP memory. For further details refer to Section 9.

5.3.4 I²C Timing

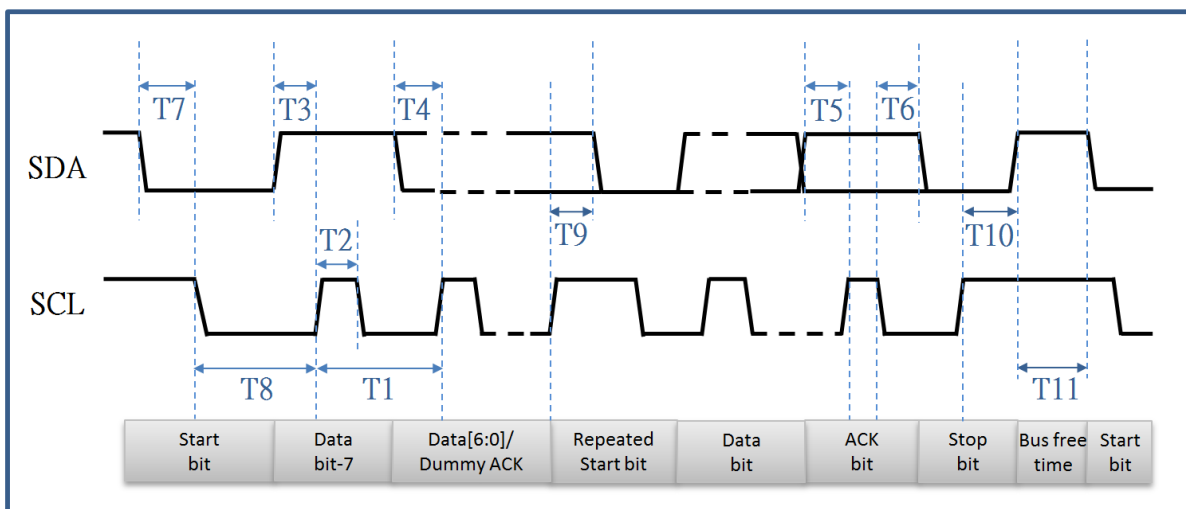

Figure 5.7 I²C Bus Timing

Parameter	Min(ns)	Typ(ns)	Max(ns)	Description
T0@48MHz		20.833		T0 is the period when operating clock=48MHz
T0@60MHz		16.666		T0 is the period when operating clock=60MHz
T0@80MHz		12.500		T0 is the period when operating clock=80MHz
Timing for I ² C Master				
T1@SM	16*T0	8*(1+N)*T0		SCK Period when I ² C as master with standard speed mode(SM).
T1@FM/HM	12*T0	6*(1+N)*T0		SCK Period when I ² C as master with FM, FM+, HS speed mode.
T2	8*T0	4*(1+N)*T0		SCK high pulse width when I ² C as master with standard speed mode(SM).
T2	4*T0	2*(1+N)*T0		SCK high pulse width when I ² C as master with FM, FM+, HS speed mode.
T3		2*(1+N)*T0		SDA output setup time to SCL rising edge when I ² C as master.
T4		2*(1+N)*T0		SDA output hold time to SCL falling edge when I ² C as master.
T5			> =0	input setup time requirement from SDA to SCL rising edge when I ² C as master.
T6			> =0	input hold time requirement from SDA to SCL falling edge when I ² C as master.
T7		2*(1+N)*T0		Start bit setup time to SCL falling edge.
T8		4*(1+N)*T0		Start bit hold time to SCL falling edge.
T9		2*(1+N)*T0		Stop bit setup time to SCL rising edge.
T10		2*(1+N)*T0		Stop bit hold time to SCL rising edge.
T11	4*(1+N)*T0			Bus free time between Start and Stop bit.
Timing for I ² C Slave				
T1	12*T0			Acceptable SCL Period when I ² C as slave device.
T2	1*T0			SCL high pulse width requirement when I ² C as slave.
T3			> =0	input setup time requirement from SDA to SCL rising edge when I ² C as slave device.
T4	1*T0			input hold time requirement from SDA to SCL falling edge when I ² C as slave device.
T5		T8 - T6		SDA output setup time to SCL rising edge.
T6	3*T0	4*T0	5*T0	SDA output hold time to SCL falling edge.

Table 5.4 I2C Timing for VCCIO=3.3V

Note that N can be ranged from 1 to 255.

5.4 GPIOs

When the configuration mode of the FT4222H is set as CNFMODE0 or CNFMODE1, a GPIO pipe will be enabled. These 4 pins, GPIO0, GPIO1, GPIO2 and GPIO3, can be set as general purpose Input/Output pins or other functions such as multi-channel SPI slave selections, I²C interface, suspend out indicator, remote wake up input or interrupt. If no functions are set on these pins, the default function is GPIO. The user can set the direction for GPIOs via the API, FT4222_GPIO_Init, defined in LibFT4222. The logic level can be read and written via the APIs, FT4222_GPIO_Read and FT4222_GPIO_Write.

The FT4222H also provides an interrupt input source for the user to utilize. GPIO3(pin-16) can be set as an interrupt input source via the API, FT4222_SetWakeUpInterrupt, defined in LibFT4222. GPIO3 can be set as a rising edge or falling edge triggered interrupt via FT_Prog. The related parameter defined in the user area is named as the interrupt trigger edge. The default setting is rising edge triggered. Details can be referenced in Table 9.1.

Figure 5.8 shows the different behaviour when GPIO3 acts as GPIO or interrupt. The interrupt is set by default as rising edge triggered. Users can choose either one for their application.

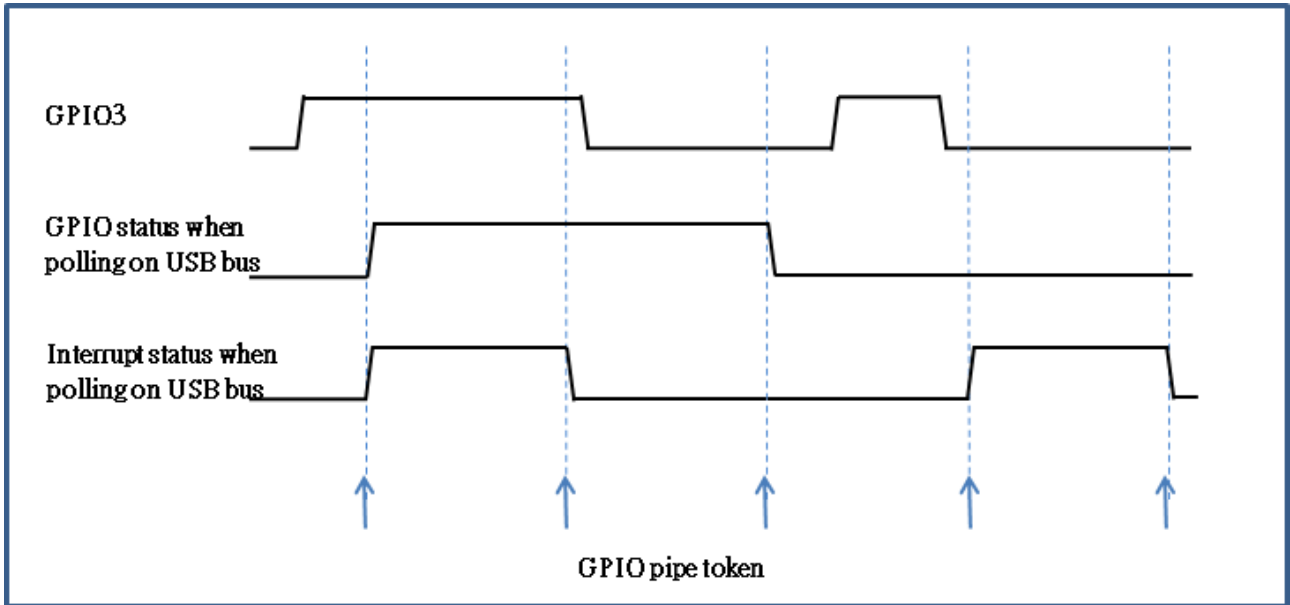

Figure 5.8 Different status when GPIO3 set as GPIO or interrupt input

6 Devices Characteristics and Ratings

6.1 Absolute Maximum Ratings

The absolute maximum ratings for the FT4222H devices are as follows. These are in accordance with the Absolute Maximum Rating System (IEC 60134). Exceeding these may cause permanent damage to the device.

Parameter	Value	Unit	Conditions
Storage Temperature	-65°C to 150°C	Degrees C	
Floor Life (Out of Bag) At Factory Ambient (30°C / 60% Relative Humidity)	168 Hours (IPC/JEDEC J-STD-033A MSL Level 3 Compliant)*	Hours	
Ambient Operating Temperature (Power Applied)	-40°C to 85°C	Degrees C	
MTTF FT4222H	TBD	Hours	
VCCIN Supply Voltage	-0.3 to +5.5	V	
VCCIO IO Voltage	-0.3 to +4.0	V	
VPP Supply Voltage	6.5±0.25	V	
DC Input Voltage – USBDP and USBDM	-0.5 to +3.63	V	
DC Input Voltage – High Impedance Bi-directional (powered from VCCIO)	-0.3 to +(VCCIO+0.5V)	V	
DC Output Current – Outputs	100 **	mA	

Table 6.1 Absolute Maximum Ratings

* If devices are stored out of the packaging beyond this time limit the devices should be baked before use. The devices should be ramped up to a temperature of +125°C and baked for up to 17 hours.

** This DC output current is also the power supply source for FT4222H operation. If it must be the source for other component on the system, it only can supply 25mA or less.

6.2 ESD and Latch-up Specifications

Description	Specification
Human Body Mode (HBM)	> ± 2kV
Machine mode (MM)	> ± 200V
Charged Device Mode (CDM)	> ± 500V
Latch-up	> ± 200mA

Table 6.2 ESD and Latch-Up Specifications

6.3 DC Characteristics

DC Characteristics (Ambient Temperature = -40°C to +85°C).

Parameter	Description	Minimum	Typical	Maximum	Units	Conditions
VCC1	VCCIN Operating Supply Voltage	4.5	5	5.5	V	VCCIN is supplied with 5V
		2.97	3.3	3.63V	V	VCCIN is supplied with 3.3V
VCC2	VCCIO Operating Supply Voltage	2.97	3.3	3.63	V	VCCIO is supplied with 3.3V
		2.25	2.5	2.75	V	VCCIO is supplied with 2.5V

Parameter	Description	Minimum	Typical	Maximum	Units	Conditions
		1.62	1.8	1.98	V	VCCIO is supplied with 1.8V
Icc1	Operating Supply Current		50	52	mA	Normal Operation at 24MHz
			62	64	mA	Normal Operation at 48MHz
			68	70	mA	Normal Operation at 60MHz
			78	80	mA	Normal Operation at 80MHz
Icc2	Suspend Supply Current		375	460	μA	USB Suspend when SPI Master
			377	465	μA	USB Suspend when SPI Slave
			386	419	μA	USB Suspend when I ² C Master
			388	456	μA	USB Suspend when I ² C Slave
3V3	3.3V regulator output	2.97	3.3	3.63	V	VCCIN must be greater than 3V3 otherwise VOUT3V3 is an input which must be driven with 3.3V

Table 6.3 Operating Voltage and Current

Parameter	Description	Minimum	Typical	Maximum	Units	Conditions
Voh	Output Voltage High	2.97	VCCIO	VCCIO	V	Ioh = +/-2mA I/O Drive strength* = 4mA
		2.97	VCCIO	VCCIO	V	I/O Drive strength* = 8mA
		2.97	VCCIO	VCCIO	V	I/O Drive strength* = 12mA
		2.97	VCCIO	VCCIO	V	I/O Drive strength* = 16mA
Vol	Output Voltage Low		0	0.4	V	Iol = +/-2mA I/O Drive strength* = 4mA
			0	0.4	V	I/O Drive strength* = 8mA
			0	0.4	V	I/O Drive strength* = 12mA
			0	0.4	V	I/O Drive strength* = 16mA
Vil	Input low Switching Threshold			0.8	V	LVTTTL
Vih	Input High Switching Threshold	2.0			V	LVTTTL
Vt	Switching Threshold		1.49		V	LVTTTL
Vt-	Schmitt trigger negative going threshold voltage		1.15		V	
Vt+	Schmitt trigger positive going threshold voltage		1.64		V	
Rpu	Input pull-up resistance	40	75	190	KΩ	Vin = 0
Rpd	Input pull-down resistance	40	75	190	KΩ	Vin = VCCIO
Iin	Input Leakage Current	-10	+/-1	10	μA	Vin = 0
Ioz	Tri-state output leakage current	-10	+/-1	10	μA	Vin = 5.5V or 0

Table 6.4 I/O Pin Characteristics VCCIO = +3.3V (except USB PHY pins)

* The I/O drive strength and slow slew-rate are configurable in the OTP memory.

Parameter	Description	Minimum	Typical	Maximum	Units	Conditions
Voh	Output Voltage High	2.25	VCCIO	VCCIO	V	Ioh = +/-2mA I/O Drive strength* = 4mA
		2.25	VCCIO	VCCIO	V	I/O Drive strength* = 8mA
		2.25	VCCIO	VCCIO	V	I/O Drive strength* = 12mA
		2.25	VCCIO	VCCIO	V	I/O Drive strength* = 16mA
Vol	Output Voltage Low		0	0.4	V	Iol = +/-2mA I/O Drive strength* = 4mA
			0	0.4	V	I/O Drive strength* = 8mA
			0	0.4	V	I/O Drive strength* = 12mA
			0	0.4	V	I/O Drive strength* = 16mA
Vil	Input low Switching Threshold			0.8	V	LVTTL
Vih	Input High Switching Threshold	1.7			V	LVTTL
Vt	Switching Threshold		1.1		V	LVTTL
Vt-	Schmitt trigger negative going threshold voltage		0.8		V	
Vt+	Schmitt trigger positive going threshold voltage		1.2		V	
Rpu	Input pull-up resistance	40	75	190	KΩ	Vin = 0
Rpd	Input pull-down resistance	40	75	190	KΩ	Vin =VCCIO
Iin	Input Leakage Current	-10	+/-1	10	μA	Vin = 0
Ioz	Tri-state output leakage current	-10	+/-1	10	μA	Vin = 5.5V or 0

Table 6.5 I/O Pin Characteristics VCCIO = +2.5V (except USB PHY pins)

* The I/O drive strength and slow slew-rate are configurable in the OTP memory.

Parameter	Description	Minimum	Typical	Maximum	Units	Conditions
Voh	Output Voltage High	1.62	VCCIO	VCCIO	V	Ioh = +/-2mA I/O Drive strength* = 4mA
		1.62	VCCIO	VCCIO	V	I/O Drive strength* = 8mA
		1.62	VCCIO	VCCIO	V	I/O Drive strength* = 12mA
		1.62	VCCIO	VCCIO	V	I/O Drive strength* = 16mA
Vol	Output Voltage Low		0	0.4	V	Iol = +/-2mA I/O Drive strength* = 4mA
			0	0.4	V	I/O Drive strength* = 8mA
			0	0.4	V	I/O Drive strength* = 12mA
			0	0.4	V	I/O Drive strength* = 16mA
Vil	Input low Switching Threshold			0.63	V	LVTTTL
Vih	Input High Switching Threshold	1.17			V	LVTTTL
Vt	Switching Threshold		0.77		V	LVTTTL
Vt-	Schmitt trigger negative going threshold voltage		0.557		V	
Vt+	Schmitt trigger positive going threshold voltage		0.893		V	
Rpu	Input pull-up resistance	40	75	190	KΩ	Vin = 0
Rpd	Input pull-down resistance	40	75	190	KΩ	Vin = VCCIO
Iin	Input Leakage Current	-10	+/-1	10	μA	Vin = 0
Ioz	Tri-state output leakage current	-10	+/-1	10	μA	Vin = 5.5V or 0

Table 6.6 I/O Pin Characteristics VCCIO = +1.8V (except USB PHY pins)

* The I/O drive strength and slow slew-rate are configurable in the OTP memory.

DC Characteristics (Ambient Temperature = -40°C to +85°C).

Parameter	Description	Minimum	Typical	Maximum	Units	Conditions
V _{PHY} , V _{PLL}	PHY Operating Supply Voltage	3.0	3.3	3.6	V	3.3V I/O
I _{CCPHY}	PHY Operating Supply Current	---	30	60	mA	High-speed operation at 480MHz
I _{CCPHY} (susp)	PHY Suspend Supply Current	---	210	250	μA	USB Suspend

Table 6.7 USB PHY Operating Voltage and Current

Parameter	Description	Minimum	Typical	Maximum	Units	Conditions
V _{HSDIFF}	High Speed Differential input voltage sensitivity	300			mV	V _{I(DP)} – V _{I(DM)} Measure at the connection of an application circuit
V _{HSCM}	Common mode voltage range of high speed data signalling	-50		500	mV	
V _{HSSQ}	High speed Squelch detection threshold			100	mV	Squelch is detected
		150			mV	Squelch is not detected
V _{HSDSC}	High Speed disconnection detection threshold	625			mV	Disconnection is detected
				525	mV	Disconnection is not detected
V _{HSOI}	High Speed idle level output voltage(Differential)	-10		10	mV	
V _{HSOL}	High Speed low level output voltage(Differential)	-10		10	mV	
V _{HSOL}	High Speed high level output voltage(Differential)	360		400	mV	
V _{CHIRPJ}	Chirp-J output voltage(Differential)	700		1100	mV	
V _{CHIRPK}	Chirp-K output voltage(Differential)	-900		-500	mV	
V _{DI}	Full Speed Differential input voltage sensitivity	0.2			V	V _{I(DP)} – V _{I(DM)}
V _{CM}	Differential common mode voltage range of full speed data signalling	0.8		2.5	V	
V _{SE}	Full Speed Single-ended receiver threshold	0.8		2.0	V	
V _{OLPHY}	Full Speed Low-level output voltage	0		0.3	V	
V _{OHPHY}	Full Speed High-level output voltage	2.8		3.6	V	

Table 6.8 USB I/O Pin (DP, DM) Characteristics

6.4 OTP Memory Reliability Characteristics

The internal 128 Bytes OTP memory has the following reliability characteristics:

Parameter	Value	Unit
Data Retention	10	Years
Write Cycle	1	Times
Read Cycle	Unlimited	Times

Table 6.9 OTP Memory Characteristics

7 FT4222H Configurations

The following sections illustrate possible USB power configurations for the FT4222H.

7.1 USB Bus Powered Configuration

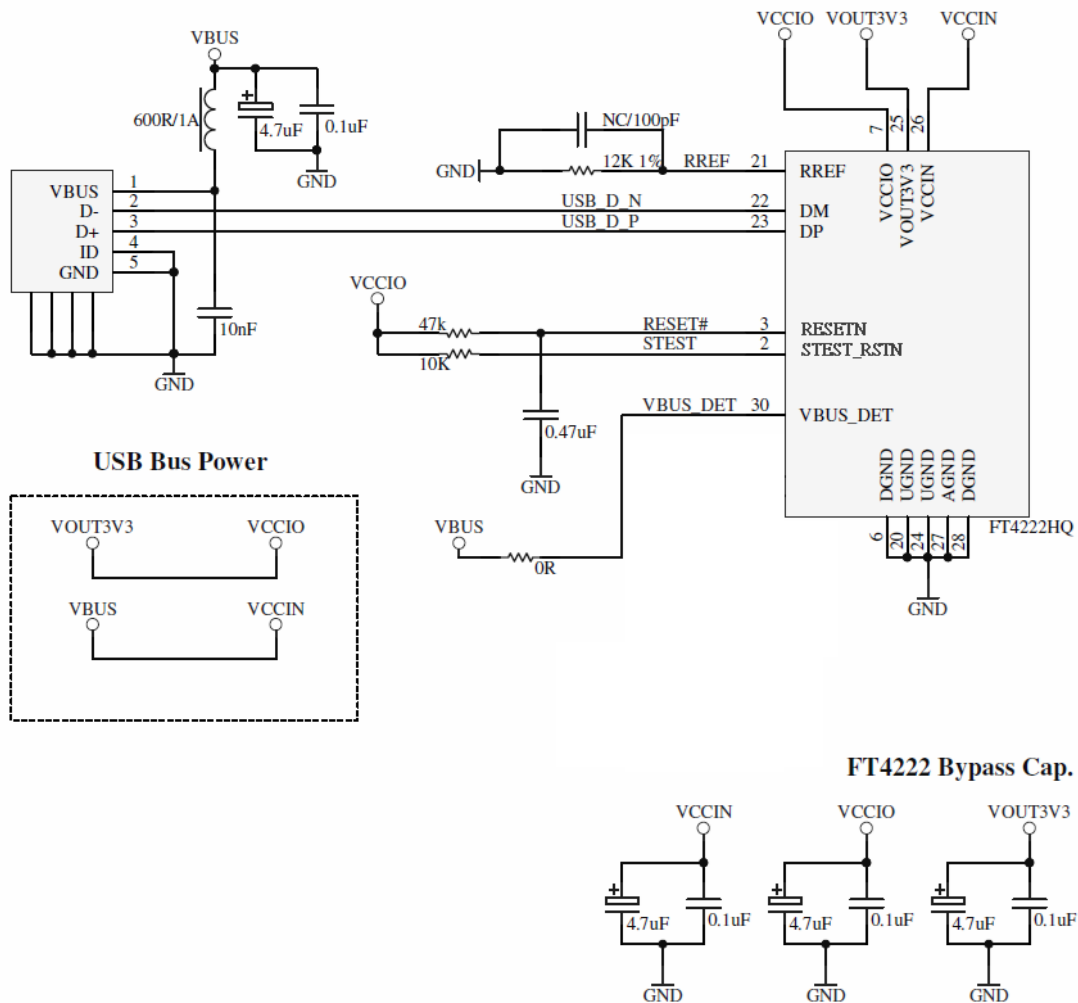

Figure 7.1 Bus Powered Configuration

Figure 7.1 illustrates the FT4222H in a typical USB2.0 bus powered design configuration. A USB bus powered device gets its power from the USB bus. Basic rules for USB bus powered devices are as follows

- i) On plug-in to USB, the device should draw no more current than 100mA.
- ii) In USB Suspend mode the device should draw no more than 2.5mA.
- iii) A bus powered, high power USB device (one that draws more than 100mA) can use SUSP_OUT(pin-15) as a power disable function and use it to keep the current below 2.5mA on USB suspend.
- iv) A device that consumes more than 100mA cannot be plugged into a USB bus powered hub.
- v) No device can draw more than 500mA from the USB bus.

The power descriptors in the internal OTP memory of the FT4222H should be programmed to match the current drawn by the device.

A ferrite bead is connected in series with the USB power supply to reduce EMI noise from the FT4222H and associated circuitry being radiated down the USB cable to the USB host. The value of the Ferrite Bead depends on the total current drawn by the application. A suitable range of Ferrite Beads is available from Steward (www.steward.com), for example Laird Technologies Part # MI0805K400R-10.

7.2 Self Powered Configuration with 5V Source Input

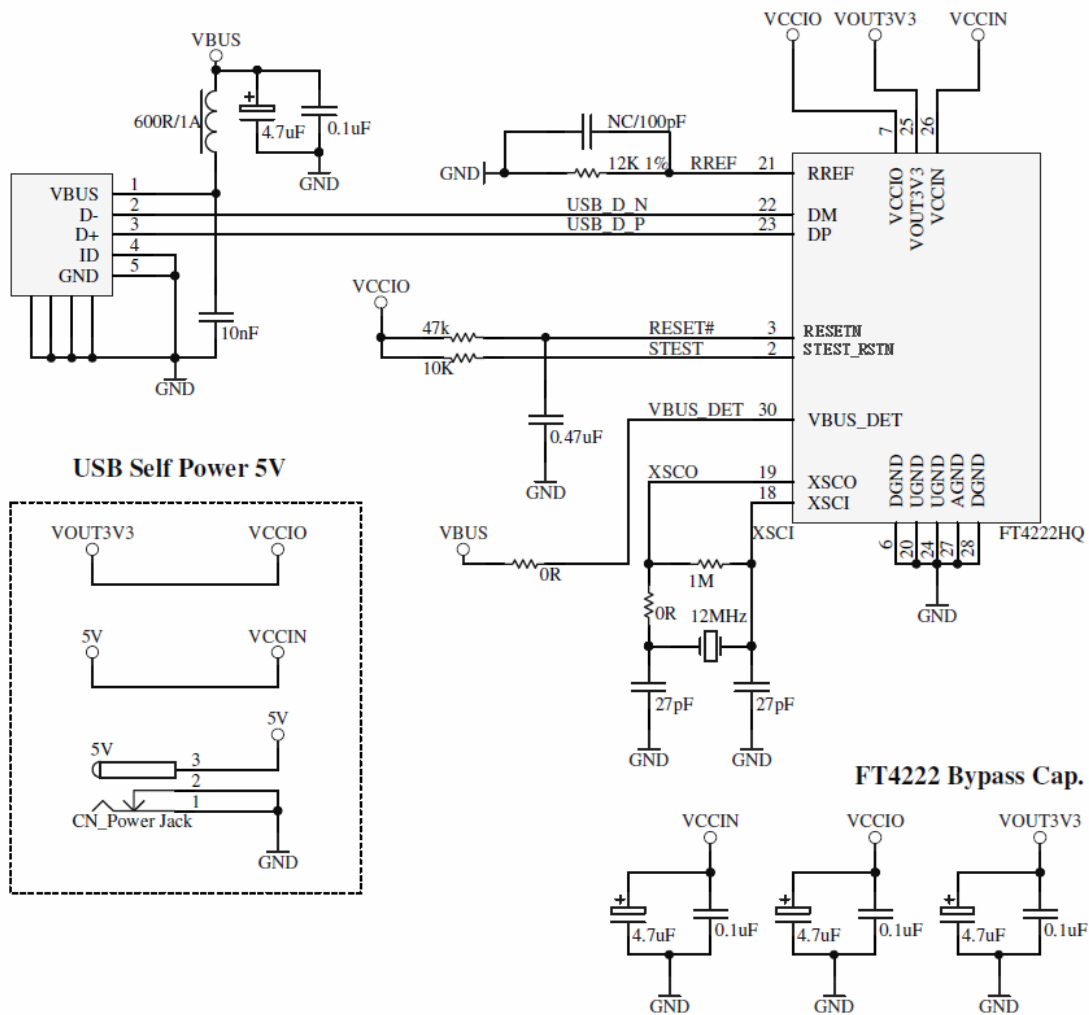

Figure 7.2 Self-Powered Configuration with 5V Source Input

Figure 7.2 illustrates the FT4222H in a typical USB2.0 self-powered configuration. A USB self-powered device gets its power from its own power supply, 5V, and does not draw current from the USB bus. The basic rules for USB self-powered devices are as follows –

- i) A self-powered device should not force current down the USB bus when the USB host or hub controller is powered down.
- ii) A self-powered device can use as much current as it needs during normal operation and USB suspend as it has its own power supply.
- iii) A self-powered device can be used with any USB host, a bus powered USB hub or a self-powered USB hub.

The power descriptor in the internal OTP memory of the FT4222H should be programmed to a value of zero (self-powered).

In order to comply with the first requirement above, the USB bus power (USB connector pin 1) is used to control the VBUS_DET pin of the FT4222H device. When the USB host or hub is powered up an internal 1.5kΩ resistor on DP is pulled up to +3.3V, thus identifying the device to the USB host or hub. When the USB host or hub is powered off, the VBUS_DET pin will be low and the FT4222H is held in a suspend state. In this state the internal 1.5kΩ resistor is not pulled up to any power supply (hub or host is powered down), so no current flows down DP via the 1.5kΩ pull-up resistor. Failure to do this may cause some USB host or hub controllers to power up erratically.

7.3 Self Powered Configuration with 3.3V Source In

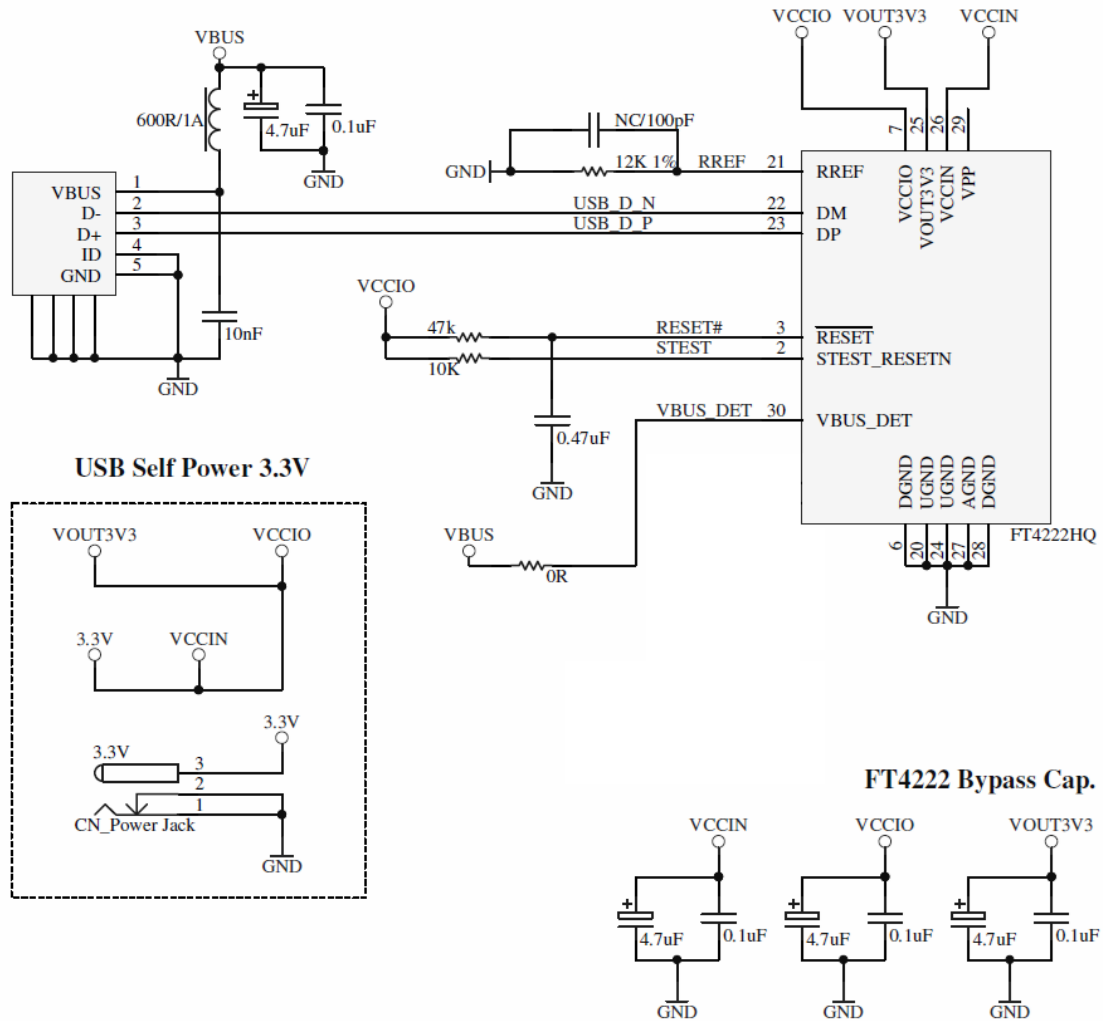

Figure 7.3 Self-Powered Configuration with 3.3V Source Input

Figure 7.3 illustrates the FT4222H in a typical USB self-powered configuration similar to Figure 7.2. The difference here is that the self-power source is 3.3V. If using 3.3V as power source in, remember to connect it to VOUT3V3 to supply actual operating voltage to USB2.0 PHY.

7.4 Crystal Oscillator Configuration

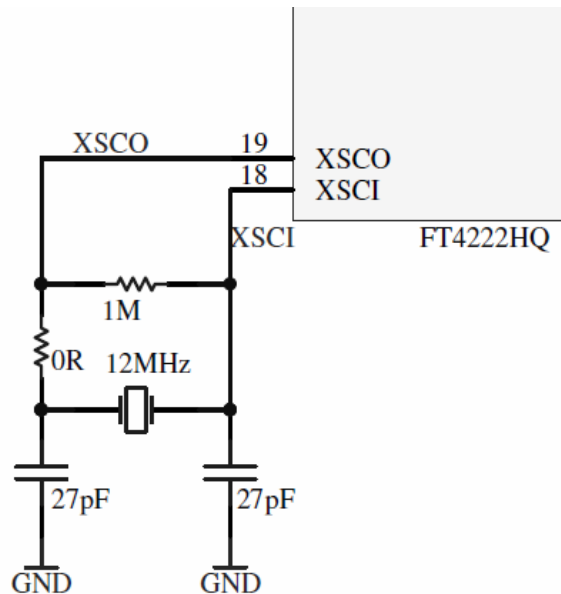

Figure 7.4 Recommended FT4222H Crystal Oscillator Configuration

Figure 7.4 illustrates how to connect the FT4222H with a 12MHz \pm 0.003% crystal. In this case loading capacitors should to be added between OSCI, OSCO and GND as shown. A value of 27pF is shown as the capacitor in the example – this will be good for many crystals but it is recommended to select the loading capacitor value based on the manufacturer’s recommendations wherever possible. It is recommended to use a parallel cut type crystal.

It is also possible to use a 12MHz oscillator with the FT4222H. In this case the output of the oscillator would drive XSCI, and XSCO should be left unconnected. The oscillator must have a CMOS output drive capability.

Parameter	Description	Minimum	Typical	Maximum	Units	Conditions
XSCI Vin	Input Voltage	2.97	3.30	3.63	V	
Fin	Input Frequency		12		MHz	+/- 30ppm
Ji	Cycle to cycle jitter		< 150		ps	

Table 7.1 XSCI Input characteristics

7.5 USB Battery Charging Detection

An addition to the USB specification (http://www.usb.org/developers/docs/devclass_docs) is to allow for additional charging profiles to be used for charging batteries in portable devices. These charging profiles do not enumerate the USB port of the peripheral. The FT4222H device will detect that a USB compliant dedicated charging port (DCP) is connected. Once detected while in suspend mode a battery charge detection signal is then provided to allow external logic to switch to charging mode as opposed to operation mode.

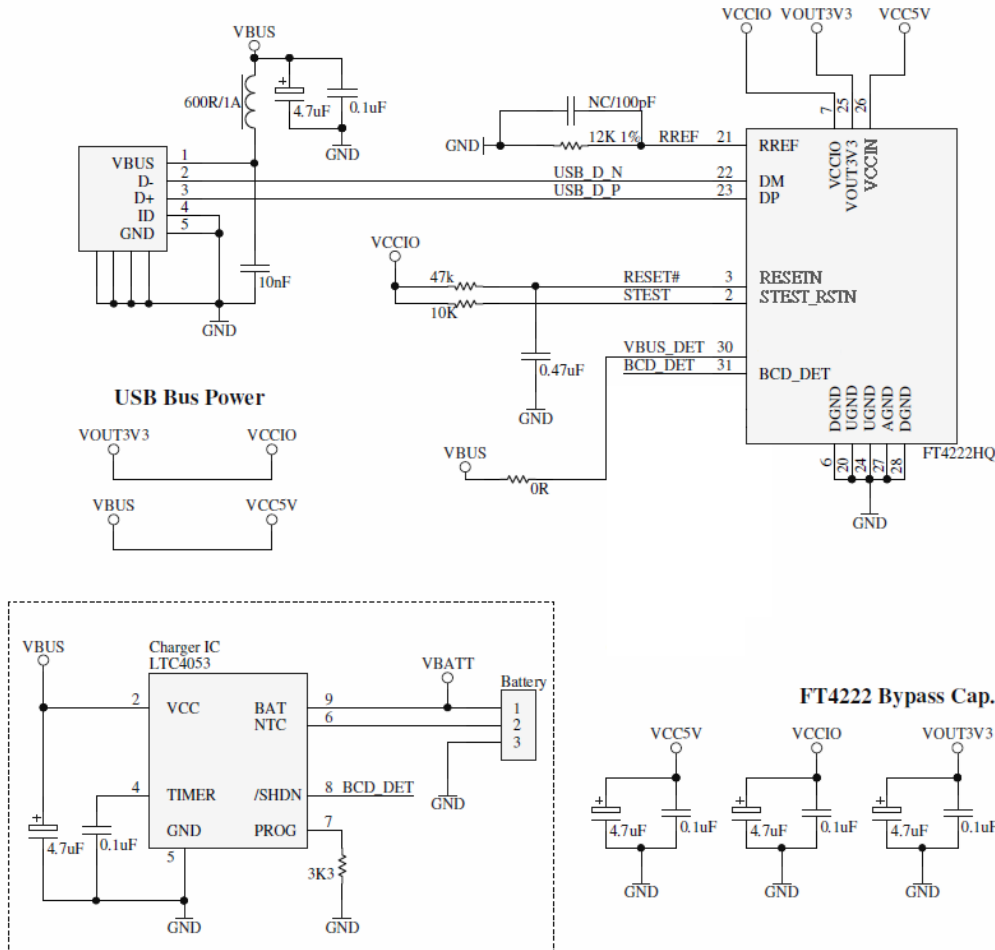

Figure 7.5 USB Battery Charging Detection

To use the FT4222H with battery charging detection, the BCD_DET pin acts as BCD Charger output to switch the external charger circuitry on. If the charging circuitry requires an active low signal to enable it, the polarity of BCD_DET can be configured in the vendor configuration area of internal OTP memory.

When connected to a USB compliant dedicated charging port (DCP, as opposed to a standard USB host) the device USB signals will be shorted together. The BCD charger signal will bring the LTC4053 out of suspend and allow battery charging to start. The charge current in the example above is 1A as defined by the resistance on the PROG pin.

To calculate the equivalent resistance on the LTC4053 PROG pin select a charge current, then $Res = 1500V/I_{chg}$.

For more configuration options of the LTC4053 refer to section 4.3 Example with 1 CBUS pin in [AN_175 Battery Charger Detection over USB with FT-X Devices](#) application note.

Note: If the FT4222H is connected to a standard host port such that the device is enumerated, the signal BCD_DET is inactive, LTC4053 is in shut down condition and the charging function will not be enabled.

8 Application Examples

The following diagrams show the possible applications of the FT4222H. In Figure 8.1, a control IC with an SPI slave interface but without a USB device interface can easily connect to USB by integrating the FT4222H into the system. With FTDI's mature and stable D2XX driver, and easy to use support library, LibFT4222, the FT4222H can easily connect an application to USB.

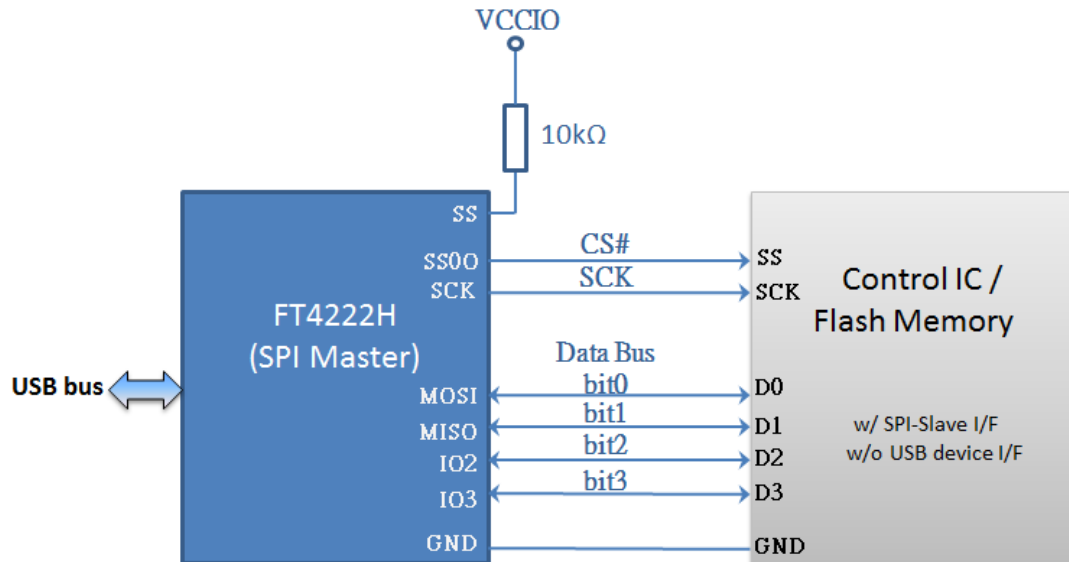

Figure 8.1 Application Example 1

In Figure 8.2, a control IC with an SPI master interface but without a USB upstream port (USB device interface) can easily connect to USB by integrating the FT4222H into the system. With a single SPI slave interface defined in FT4222H and easy to use API defined in LibFT4222, it is easy to connect an application to USB via FT4222H.

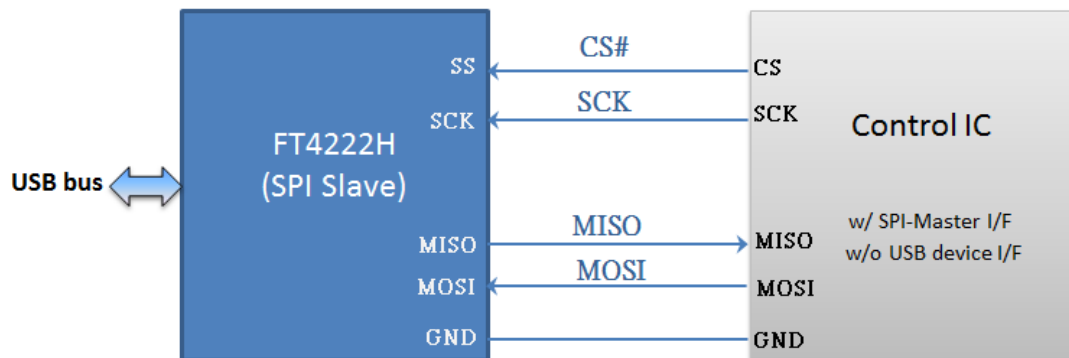

Figure 8.2 Application Example 2

In Figure 8.3, a control IC with an I²C slave interface but without a USB device interface can easily connect to USB by integrating the FT4222H into the system. With FTDI’s mature and stable D2XX driver, and easy to use support library, LibFT4222, the FT4222H can easily connect an application to USB. With a suitable pull-high resistor value on I²C bus, the transfer speed at this I²C interface can be sped up to the HS mode defined in I²C specification.

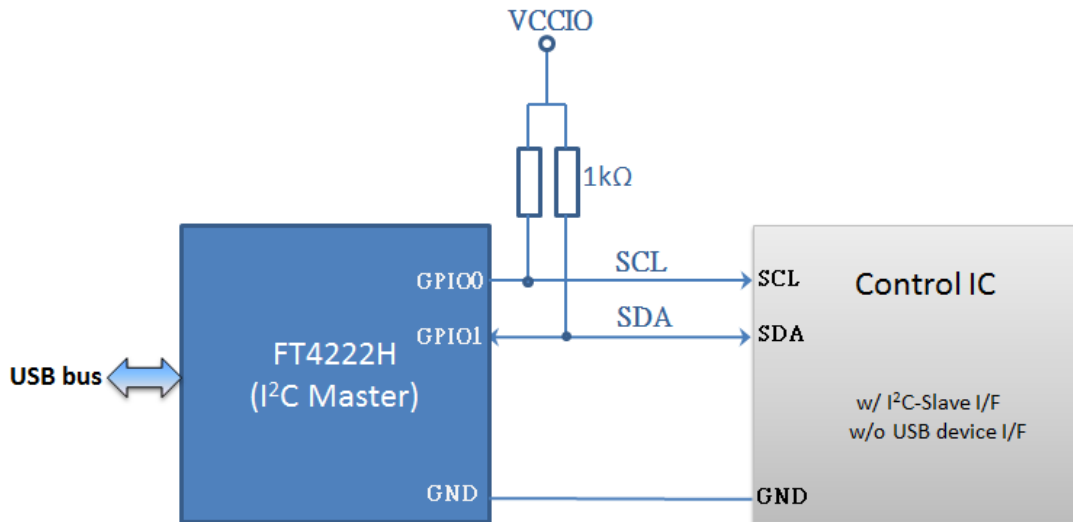

Figure 8.3 Application Example 3

In Figure 8.4, a control IC with an I²C master interface but without a USB upstream port (USB device interface) can easily connect to USB by integrating the FT4222H into the system. With an I²C slave interface defined in the FT4222H and easy to use API defined in LibFT4222, it is easy to connect an application to USB via the FT4222H. With a suitable pull-high resistor value on I²C bus, the transfer speed at this I²C interface can be sped up to the HS mode.

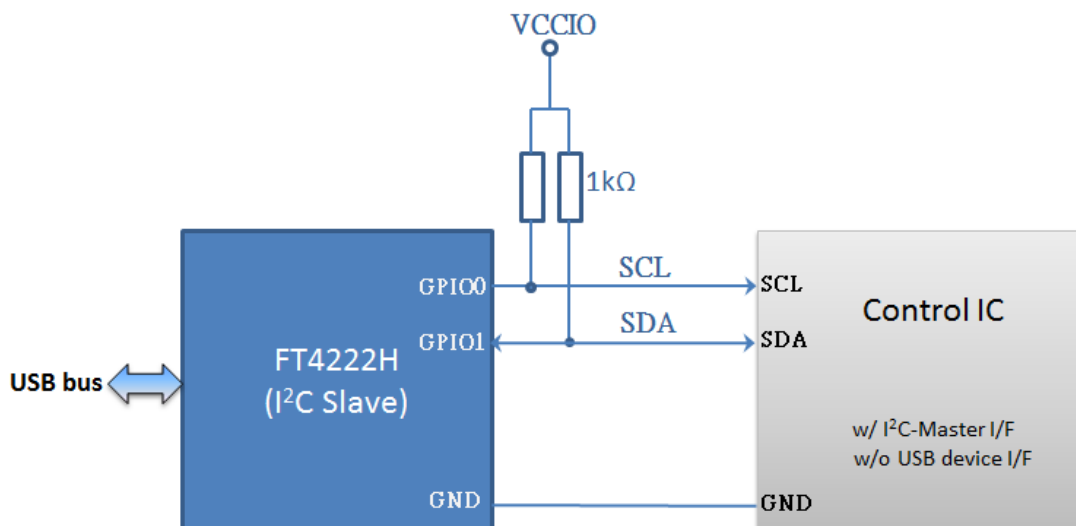

Figure 8.4 Application Example 4

9 Internal OTP Memory Configuration

The FT4222H includes an internal OTP memory which holds the USB configuration descriptors, other configuration data for the chip and also user data areas. Following a power-on reset or a USB reset the FT4222H will scan its internal OTP memory and read the USB configuration descriptors stored there.

In many cases, the default values programmed into the OTP memory will be suitable and no re-programming will be necessary. The defaults can be found in Section 9.1.

The OTP memory in the FT4222H can be programmed over USB if the values need to be changed for a particular application. Further details of this are provided from section 9.2 onwards.

Users who do not have their own USB Vendor ID but who would like to use a unique Product ID in their design can apply to FTDI for a free block of unique PIDs. See [TN_100 USB Vendor ID/Product ID Guidelines](#) for more details.

9.1 Default Values

The default factory programmed values of the internal OTP memory are shown in Table 9.1.

Parameter	Default Value	Notes
Device Type	FT4222H	Read-Only. Indicate the Chip is FT4222H.
USB Vendor ID (VID)	0403h	USB Vendor ID. Defined in the USB device descriptor. The format is 16-bit hex coded and default is set as FTDI VID.
USB Product ID (PID)	601Ch	USB Product ID. Defined in the USB device descriptor The format is 16-bit hex coded and default is set as FTDI VID.
USB Version	0200h	Read-only. Returns the USB 2.0 device descriptor to the host. Note: FT4222H is a Hi-speed USB2.0 device. If the connected host/hub is full speed only, the FT4222H will operate at full speed without changing this USB version parameter to USB1.1.
Power Source	Bus Powered	Define whether the power source is from the USB bus or a local source.
Max Bus Power Current	100mA	The max power that will be drawn from VBUS when using bus power. Range from 0~500mA. If the power source is defined as self-powered, it must be set as 0mA.
Remote Wake Up	Enable	Define if the FT4222H supports remote wake up or not.
Manufacturer Name	FTDI	Describing the manufacturer. A string descriptor defined in USB device descriptors.
Product Description	FT4222	Describing the product. A string descriptor defined in USB device descriptors.
Serial Number Enabled?	No	Enable the string descriptor for serial number or not.
Serial Number	None	A unique serial number is generated and programmed into the OTP memory. Refer to the Utility FT_PROG for details.
Enable Suspend Out	enable	Set GPIO2(pin-15) as USB suspend indicator.
Suspend Out Polarity	active-high	Set the polarity on GPIO2 pin for indicating suspend out. Default is set as active-high.
I ² C Slave Address	40h	Set the I ² C slave address when I ² C Slave function is enabled. Range from 00h ~ 7Fh.
SPI Drive Strength	4mA	Adjustable drive strength for SPI related pins SCK, MISO/MOSI/IO2/IO3, SS00. Drive strength can be set as 4mA, 8mA, 12mA and 16mA.

Parameter	Default Value	Notes
SPI Weak Pullup/Pulldown	disable	Enable the weak pullup / pulldown resistor on the pin SS(pin-32). Default is disabled (without any pull).
SPI Slew Rate Enable?	disable	Set the slew rate control for SPI related pins SCK, MISO, MOSI, SS00, IO2, IO3. Default is disabled.
SPI Suspend Mode	disable(tri-state)	Mode selection for I/O status of SPI related pins SCK, MISO, MOSI, IO2, IO3, SS00 when USB suspends. Refer to Table 5.8 for defaults.
SPI Suspend	No change	Define the behaviour of SPI related pins MISO, MOSI, IO2/IO3, SS00 when USB suspend happens. Behaviour can be set as No change, push-high or push-low when SPI Suspend Mode is set as Enable SPI pin control.
GPIO Drive Strength	4mA	Adjustable drive strength for GPIO related pins GPIO0, GPIO1, GPIO2, GPIO3. Drive strength can be set as 4mA, 8mA, 12mA and 16mA.
GPIO Open Drain	disable	Set the behaviour of GPIO pins as open-drain. Default is disabled(GPIO acts as push-pull mode).
GPIO Weak Pullup/Pulldown	disable	Enable the weak pullup / pulldown resistor on the pins GPIO0, GPIO1, GPIO2, GPIO3. Default is disabled (without any pull).
GPIO Suspend	input(tri-state)	Define the behaviour of GPIO related pins GPIO0, GPIO1, GPIO2, GPIO3 when suspend happens. Pins can be set as No change, input as tri-state, push-high or push-low.
BCD_DET Function Disable?	No	Battery Charger Detection function can be disabled on BCD_DET pin (pin-31).
BCD_DET Drive Strength	4mA	Adjustable drive strength for BCD_DET pin. Drive strength can be set as 4mA, 8mA, 12mA and 16mA.
BCD_DET Polarity	active-high	Set the polarity on BCD_DET pin for indicating battery charge detected. Default is set as active-high.
Interrupt trigger edge	rising edge	Define the interrupt trigger edge when GPIO3 (pin-16) is set as INTR/WAKEUP function. Default is rising-edge triggered.

Table 9.1 Default Internal OTP Memory Configuration

9.2 Method of Programming the OTP Memory

9.2.1 Programming the OTP memory over USB

The OTP memory on a FT4222H device can be programmed over USB, however, the UMFT4222PROG Programmer Module should be used to program the IC. Failure to use this module can result in corruption of the OTP memory which is unrecoverable.

The OTP memory on a FT4222H device can be programmed over USB. This method is the same as for the MTP on other FTDI devices such as the FT-X series. Please note that in order to program OTP, the FT4222H requires an additional programming voltage (6.5V) on its VPP pin. The programming board, UMFT4222PROG, supplies an easy connection bridge between the FT4222H and a USB host for boosting the VBUS up to 6.5V and for communicating with the programming utility FT_Prog. Further details may be found in the datasheet [UMFT4222PROG](#), the FT4222H programming module.

The FT_Prog utility is provided free-of-charge from the FTDI website and can be found at the link below. The user guide is also available at this link.

https://ftdichip.com/utilities/#ft_prog

Additionally, D2XX commands can be used to program the OTP memory from within the user applications. For more information on the commands available, please see the [D2XX Programmers Guide](#).

10 Package Parameters

The FT4222H is available in a VQFN-32 package. The solder reflow profile for VQFN-32 is described in Section 10.3.

10.1 VQFN-32 Package Mechanical Dimensions

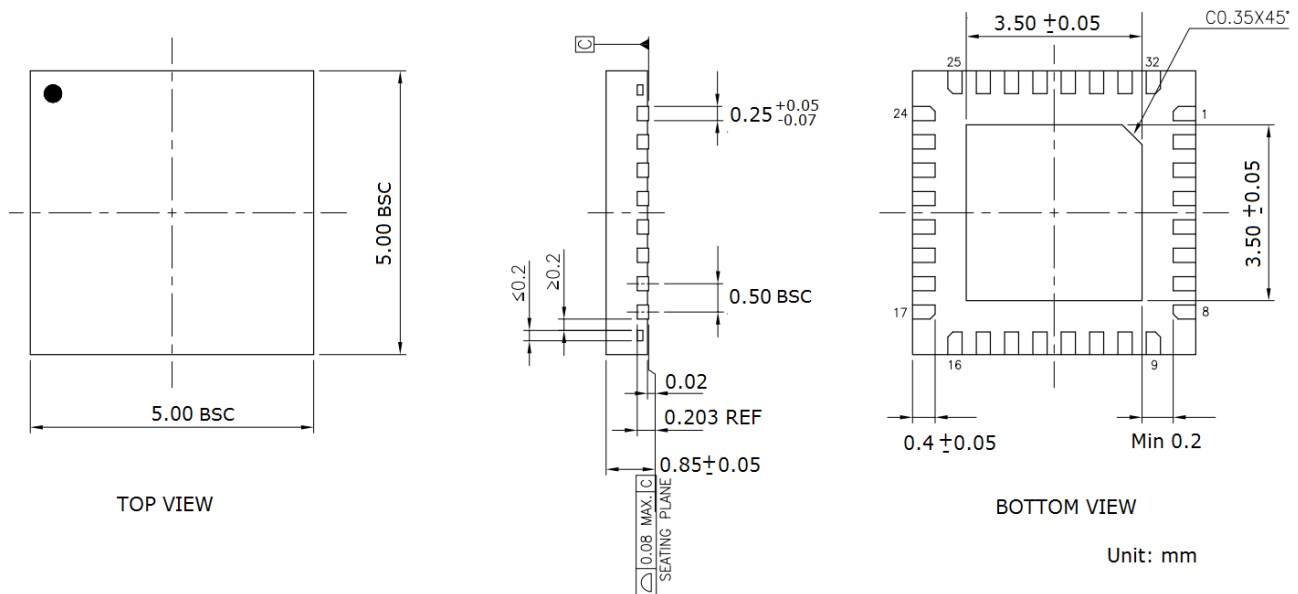

Figure 10.1 VQFN-32 Package Dimensions

The FT4222H is supplied in a RoHS compliant leadless VQFN-32 package. The package is lead (Pb) free, and uses a 'green' compound. The package is fully compliant with European Union directive 2002/95/EC.

This package is nominally 5.00mm x 5.00mm. The solder pads are on a 0.5mm pitch. The above mechanical drawing shows the VQFN-32 package. All dimensions are in millimetres.

The centre pad on the base of the FT4222H is internally connected to GND and the PCB should not have signal tracking on the top layer under this area. Connect to GND.

10.2 VQFN-32 Package Markings

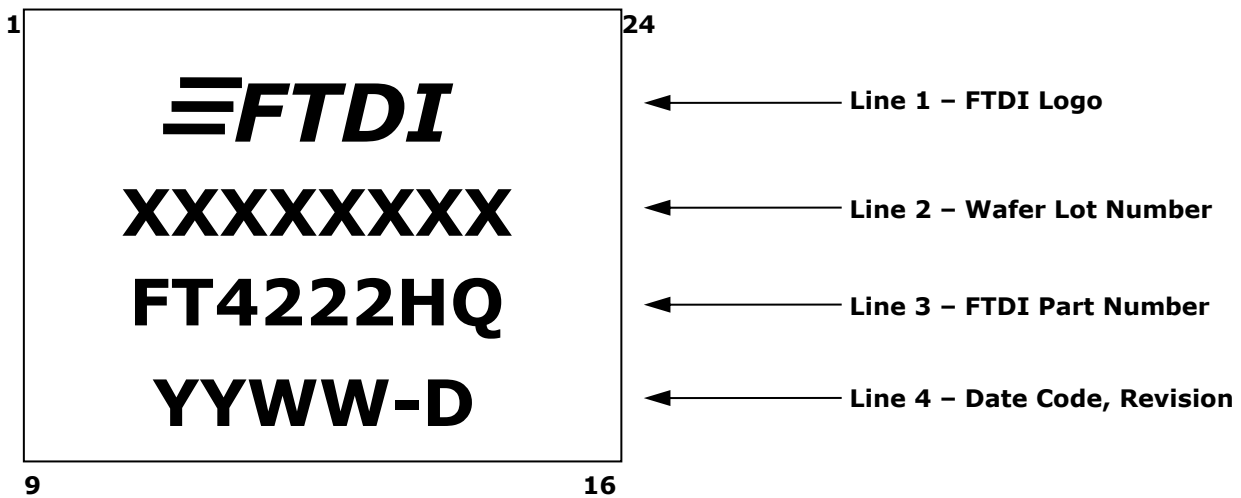

Figure 10.2 VQFN-32 Package Markings

The date code format is **YYWW** where WW = 2-digit week number, YY = 2-digit year number. This is followed by the revision number.

The code **XXXXXXXX** is the manufacturing LOT code.

10.3 Solder Reflow Profile

The FT4222H is supplied in a Pb free VQFN-32 package. The recommended solder reflow profile is shown in Figure 10.3.

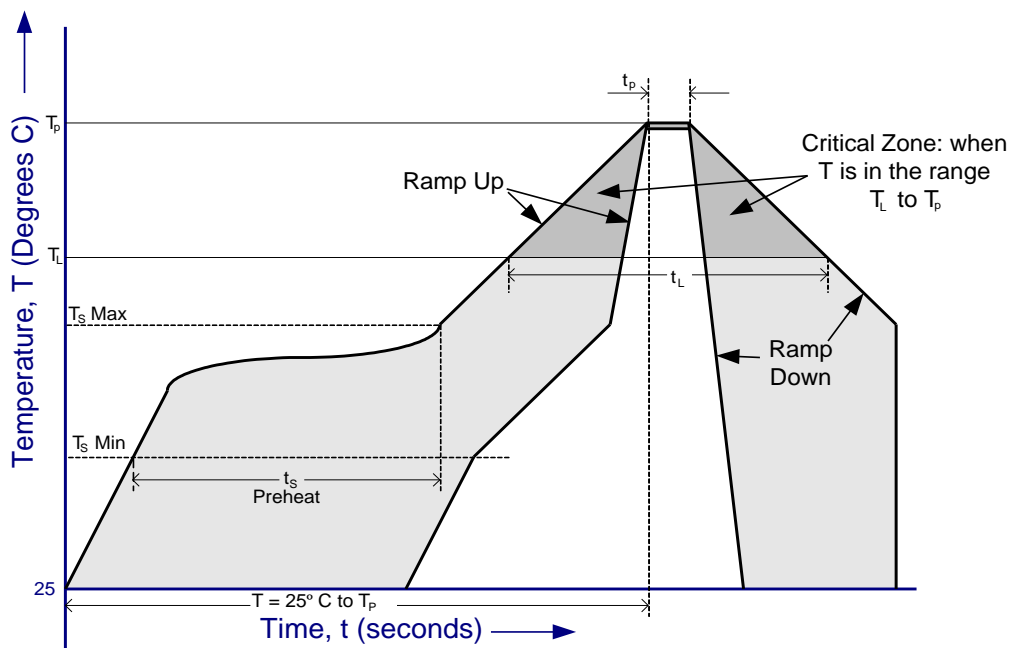

Figure 10.3 FT4222H Solder Reflow Profile

The recommended values for the solder reflow profile are detailed in Table 10.1. Values are shown for both a completely Pb free solder process (i.e. the FT4222H is used with Pb free solder), and for a non-Pb free solder process (i.e. the FT4222H is used with non-Pb free solder).

Profile Feature	Pb Free Solder Process	Non-Pb Free Solder Process
Average Ramp Up Rate (T_s to T_p)	3°C / second Max.	3°C / Second Max.
Preheat - Temperature Min (T_s Min.) - Temperature Max (T_s Max.) - Time (t_s Min to t_s Max)	150°C 200°C 60 to 120 seconds	100°C 150°C 60 to 120 seconds
Time Maintained Above Critical Temperature T_L : - Temperature (T_L) - Time (t_L)	217°C 60 to 150 seconds	183°C 60 to 150 seconds
Peak Temperature (T_p)	260°C	240°C
Time within 5°C of actual Peak Temperature (t_p)	20 to 40 seconds	20 to 40 seconds
Ramp Down Rate	6°C / second Max.	6°C / second Max.
Time for $T = 25^\circ\text{C}$ to Peak Temperature, T_p	8 minutes Max.	6 minutes Max.

Table 10.1 Reflow Profile Parameter Values

11 Contact Information

Head Office – Glasgow, UK

Future Technology Devices International Limited
Unit 1, 2 Seaward Place, Centurion Business Park
Glasgow G41 1HH
United Kingdom
Tel: +44 (0) 141 429 2777
Fax: +44 (0) 141 429 2758

E-mail (Sales) sales1@ftdichip.com
E-mail (Support) support1@ftdichip.com
E-mail (General Enquiries) admin1@ftdichip.com

Branch Office – Tigard, Oregon, USA

Future Technology Devices International Limited (USA)
7130 SW Fir Loop
Tigard, OR 97223-8160
USA
Tel: +1 (503) 547 0988
Fax: +1 (503) 547 0987

E-mail (Sales) us.sales@ftdichip.com
E-mail (Support) us.support@ftdichip.com
E-mail (General Enquiries) us.admin@ftdichip.com

Branch Office – Taipei, Taiwan

Future Technology Devices International Limited (Taiwan)
2F, No. 516, Sec. 1, NeiHu Road
Taipei 114
Taiwan, R.O.C.
Tel: +886 (0) 2 8797 1330
Fax: +886 (0) 2 8751 9737

E-mail (Sales) tw.sales1@ftdichip.com
E-mail (Support) tw.support1@ftdichip.com
E-mail (General Enquiries) tw.admin1@ftdichip.com

Branch Office – Shanghai, China

Future Technology Devices International Limited (China)
Room 1103, No. 666 West Huaihai Road,
Shanghai, 200052
China
Tel: +86 21 62351596
Fax: +86 21 62351595

E-mail (Sales) cn.sales@ftdichip.com
E-mail (Support) cn.support@ftdichip.com
E-mail (General Enquiries) cn.admin@ftdichip.com

Web Site

<http://ftdichip.com>

Distributor and Sales Representatives

Please visit the Sales Network page of the [FTDI Web site](#) for the contact details of our distributor(s) and sales representative(s) in your country.

System and equipment manufacturers and designers are responsible to ensure that their systems, and any Future Technology Devices International Ltd (FTDI) devices incorporated in their systems, meet all applicable safety, regulatory and system-level performance requirements. All application-related information in this document (including application descriptions, suggested FTDI devices and other materials) is provided for reference only. While FTDI has taken care to assure it is accurate, this information is subject to customer confirmation, and FTDI disclaims all liability for system designs and for any applications assistance provided by FTDI. Use of FTDI devices in life support and/or safety applications is entirely at the user's risk, and the user agrees to defend, indemnify and hold harmless FTDI from any and all damages, claims, suits or expense resulting from such use. This document is subject to change without notice. No freedom to use patents or other intellectual property rights is implied by the publication of this document. Neither the whole nor any part of the information contained in, or the product described in this document, may be adapted or reproduced in any material or electronic form without the prior written consent of the copyright holder. Future Technology Devices International Ltd, Unit 1, 2 Seaward Place, Centurion Business Park, Glasgow G41 1HH, United Kingdom. Scotland Registered Company Number: SC136640

Appendix A – References

Document References

[AN_107 Advanced Driver Options](#)
[AN_121 FTDI Device EEPROM User Area Usage](#)
[AN_175 Battery Charger Detection over USB with FT-X Devices](#)
[AN_184 FTDI Device Input Output Pin States](#)
[AN_329 User Guide for LibFT4222](#)
[DS_UMFT4222EV](#)
[DS_UMFT4222PROG](#)
[D2XX Programmers Guide](#)
[Installation Guides](#)
[TN_100 USB Vendor ID/Product ID Guidelines](#)
https://ftdichip.com/utilities/#ft_prog
<https://www.i2c-bus.org/specification/>
http://www.usb.org/developers/docs/devclass_docs/

Acronyms and Abbreviations

Terms	Description
DCP	Dedicated Charging Port
EHCI	Enhanced Host Controller Interface
I ² C	Inter-Integrated Circuit
LDO	Low Drop Out regulator
OTP	One Time Programmable
OHCI	Open Host Controller Interface
PCB	Printed Circuit Board
POR	Power On Reset
RoHS	Restriction of Hazardous Substances Directive
SPI	Serial Peripheral Interface Bus
USB	Universal Serial Bus
UHCI	Universal Host Controller Interface
UTMI	Universal Transceiver Marocell Interface
VQFN	Very Thin Quad Flat Non-Leaded Package
XHCI	eXtensible Host Controller Interface

Appendix B - List of Figures and Tables

List of Figures

Figure 2.1 FT4222H Block Diagram	4
Figure 3.1 Pin Configuration VQFN-32 (Top-Down View)	7
Figure 5.1 QuadSPI Bus Protocol when Transferring in Single Mode.....	16
Figure 5.2 QuadSPI Bus Protocol when Transferring in Quad Mode	16
Figure 5.3 SCK Transfer Format when CPHA=0.....	17
Figure 5.4 SCK Transfer Format when CPHA=1.....	17
Figure 5.5 SPI Timing.....	18
Figure 5.6 I ² C Bus Protocol	20
Figure 5.7 I ² C Bus Timing	21
Figure 5.8 Different status when GPIO3 set as GPIO or interrupt input	23
Figure 7.1 Bus Powered Configuration	31
Figure 7.2 Self-Powered Configuration with 5V Source Input	32
Figure 7.3 Self-Powered Configuration with 3.3V Source Input	33
Figure 7.4 Recommended FT4222H Crystal Oscillator Configuration	34
Figure 7.5 USB Battery Charging Detection	35
Figure 8.1 Application Example 1	36
Figure 8.2 Application Example 2	36
Figure 8.3 Application Example 3	37
Figure 8.4 Application Example 4	37
Figure 10.1 VQFN-32 Package Dimensions	41
Figure 10.2 VQFN-32 Package Markings.....	42
Figure 10.3 FT4222H Solder Reflow Profile.....	42

List of Tables

Table 3.1 FT4222H Pin Description.....	9
Table 4.1 SCK Operating Frequency in SPI Master Mode	12
Table 4.2 Max. Acceptable Operating Frequency on SCK in SPI Slave Mode.....	12
Table 5.1 FT4222H Pin Functions on Chip Configuration Mode	14
Table 5.2 SPI Timing for VCCIO=3.3V with 5pF output pin load	18
Table 5.3 SPI Timing for VCCIO=1.8V with 5pF output pin load	19
Table 5.4 I2C Timing for VCCIO=3.3V	22
Table 6.1 Absolute Maximum Ratings	24
Table 6.2 ESD and Latch-Up Specifications	24
Table 6.3 Operating Voltage and Current	25
Table 6.4 I/O Pin Characteristics VCCIO = +3.3V (except USB PHY pins)	26
Table 6.5 I/O Pin Characteristics VCCIO = +2.5V (except USB PHY pins)	27
Table 6.6 I/O Pin Characteristics VCCIO = +1.8V (except USB PHY pins)	28
Table 6.7 USB PHY Operating Voltage and Current.....	29



Table 6.8 USB I/O Pin (DP, DM) Characteristics	29
Table 6.9 OTP Memory Characteristics.....	30
Table 7.1 XSCI Input characteristics.....	34
Table 9.1 Default Internal OTP Memory Configuration	39
Table 10.1 Reflow Profile Parameter Values.....	43

Appendix C - Revision History

Document Title: FT4222H USB2.0 TO QUADSPI/I2C BRIDGE IC Datasheet
 Document Reference No.: FT_001011
 Clearance No.: FTDI# 405
 Product Page: <https://ftdichip.com/product-category/products/ic/>
 Document Feedback: [Send Feedback](#)

Revision	Changes	Date
1.0	Initial Release	2014-09-16
1.1	Revised Release	2015-09-10
1.2	Updated section 9.2	2015-12-21
1.2.1	Updated the value of T6 in table 5.2	2015-12-24
1.3	Updated table 4.1, Fig 5.2, 10.2 for rev C enhancements	2016-10-17
1.4	Updated TID of USB Logo in section1.3 for Rev D, the timing spec in Table 5.2, 5.3 and Figure10.2 for rev D	2018-04-02
1.5	Updated Figure 10.1 VQFN-32 Package Dimensions	2019-02-27
1.6	Removed "Device supplied pre-programmed with unique USB serial number" from the first page. Updated Driver Support in section 1.1. Updated SPI Master maximum SCK to 40MHz. Updated I2C master/salve bit rate maximum to 3.4Mbit/s.	20-05-2024