



**Future Technology Devices International Ltd**

**TTL-232R**



**TTL to USB Serial Converter Range of  
Cables  
Datasheet**

Neither the whole nor any part of the information contained in, or the product described in this manual, may be adapted or reproduced in any material or electronic form without the prior written consent of the copyright holder. This product and its documentation are supplied on an as-is basis and no warranty as to their suitability for any particular purpose is either made or implied. Future Technology Devices International Ltd will not accept any claim for damages howsoever arising as a result of use or failure of this product. Your statutory rights are not affected. This product or any variant of it is not intended for use in any medical appliance, device or system in which the failure of the product might reasonably be expected to result in personal injury. This document provides preliminary information that may be subject to change without notice. No freedom to use patents or other intellectual property rights is implied by the publication of this document. Future Technology Devices International Ltd, Unit 1, 2 Seaward Place, Centurion Business Park, Glasgow G41 1HH United Kingdom. Scotland Registered Company Number: SC136640

# 1 Description

The **TTL-232R** cables are a family of USB to TTL serial UART converter cables incorporating FTDI's FT232RQ USB to Serial UART interface IC device which handles all the USB signalling and protocols. The cables provide a fast, simple way to connect devices with a TTL level serial interface to USB.

Each TTL-232R cable contains a small internal electronic circuit board, utilising the FT232RQ, which is encapsulated into the USB connector end of the cable. The FT232RQ datasheet, [DS\\_FT232R](https://ftdichip.com/DS_FT232R), is available at <https://ftdichip.com/>. The other end of the cable comes with a selection of different connectors supporting various applications – see Table 1.1

Cables are FCC, CE, UKCA, RoHS compliant and are available at TTL levels of +5V and +3.3V.

Cables are available with either a 6-way SIL,0.1" pitch connector, a 3.5mm Audio Jack, an 8-way, keyed 2mm pitch connector (intended for use with VMUSIC2 or VDRIVE2) or bare, tinned wire ended connections (see Table 1.1)

The USB side of the cable is USB powered and USB 2.0 full speed compatible. Each cable is 1.8m long and supports a data transfer rate up to 3 Mbaud. Each cable supports the FTDIChip-ID™, with a unique USB serial number programmed into the FT232RQ. This feature can be used to create a security or password protected file transfer access using the cable. Further information and examples on this feature are available at <https://ftdichip.com/> under [FTDIChip-ID Projects](#).

The TTL-232R cables require USB drivers, available free from <https://ftdichip.com/>, which are used to make the FT232RQ in the cable appear as a virtual COM port (VCP). This then allows the user to communicate with the USB interface via a standard PC serial emulation port (for example TTY). Another FTDI USB driver, the D2XX driver, can also be used with application software to directly access the FT232RQ on the cable through a DLL. This is illustrated in the Figure 1.1

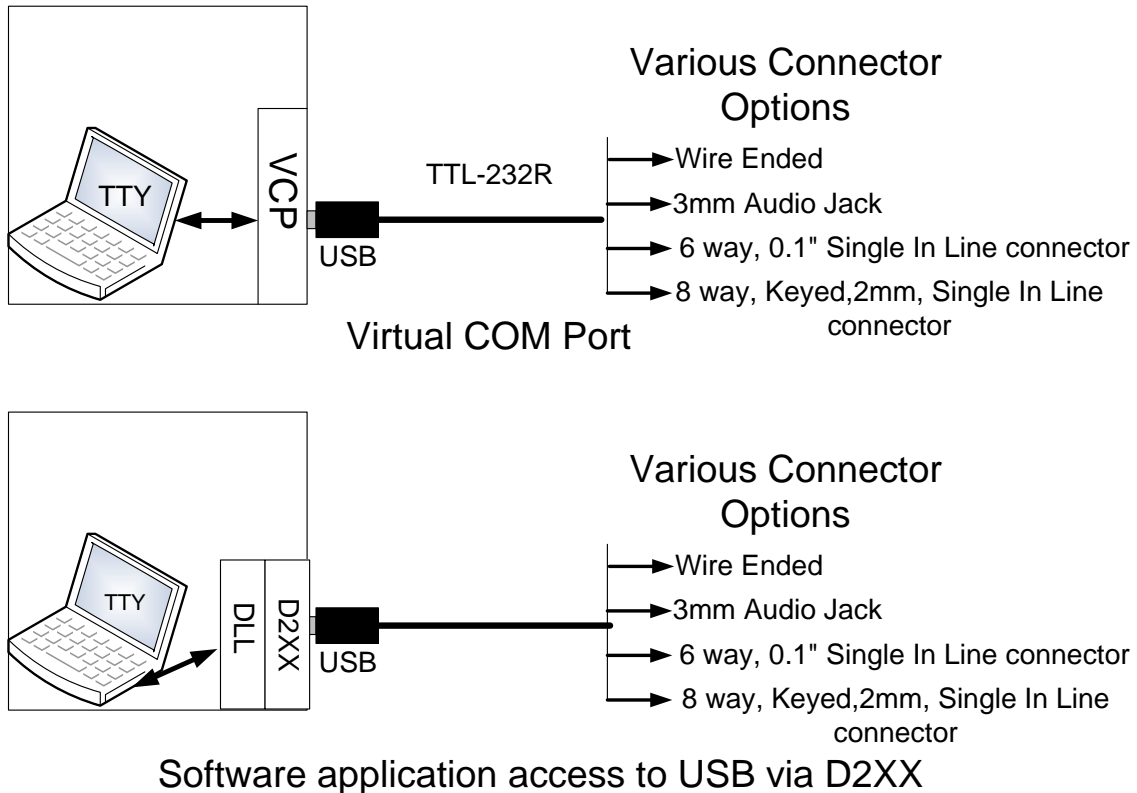

**Figure 1.1 Using the TTL-232R Cable**

## 1.1 Available Cables and Part Numbers

The following Table 1.1 gives details of the available TTL-232R cables.

Part Number	Description	End Connector*	Cable details
TTL-232R-5V**	USB to UART cable with +5V TTL level UART signals.	6 pin SIL, 0.1" pitch	6 core, UL2464 24 AWG, diam=5mm
TTL-232R-3V3	USB to UART cable with +3.3V TTL level UART signals.	6 pin SIL, 0.1" pitch	6 core, UL2464 24 AWG, diam=5mm
TTL-232R-5V-WE**	USB to UART cable with +5V TTL level UART signals.	Wire Ended (no connector)	6 core, UL2464 24 AWG, diam=5mm
TTL-232R-3V3-WE	USB to UART cable with +3.3V TTL level UART signals.	Wire Ended (no connector)	6 core, UL2464 24 AWG, diam=5mm
TTL-232R-5V-AJ**	USB to UART cable with +5V TTL level UART signals.	3.5mm Audio Jack	2 core and spiral, 24 AWG diam=5mm
TTL-232R-3V3-AJ	USB to UART cable with +3.3V TTL level UART signals.	3.5mm Audio Jack	2 core and spiral, 24 AWG diam=5mm
TTL-232R-3V3-2mm	USB to UART cable with +3.3V TTL level UART signals.	8 way, keyed, 2mm connector for use with FTDI VDRIVE2 or VMUSIC2 modules	7 core, UL2464 26 AWG, diam=5mm

**Table 1.1 TTL-232R Cables Descriptions and Part Numbers**

\* FTDI supports customised end connector designs. For more information, please contact FTDI Sales Team ([sales1@ftdichip.com](mailto:sales1@ftdichip.com))

\*\* These cables are identical to cables which do not have the "5V" in the part number. The 5V was added to the part number for clarity.

## 1.2 Certifications

FTDI TTL-232R range of cables are fully RoHS compliant as well as CE, UKCA and FCC certified.



## 1.3 USB Compliant

The TTL-232R cables are fully compliant with the USB 2.0 specification.



## Table of Contents

<b>1</b>	<b>Description.....</b>	<b>2</b>
1.1	Available Cables and Part Numbers.....	3
1.2	Certifications .....	4
1.3	USB Compliant .....	4
<b>2</b>	<b>Typical Applications .....</b>	<b>7</b>
2.1	Driver Support .....	7
	Royalty free VIRTUAL COM PORT (VCP) and D2XX Direct Drivers are available for the following Operating Systems (OS):.....	7
•	Windows .....	7
•	Linux.....	7
•	Mac .....	7
	<a href="https://ftdichip.com/drivers/">https://ftdichip.com/drivers/</a> .....	7
2.2	Features.....	8
<b>3</b>	<b>Features of FT232RQ applicable to TTL-232R Cables.....</b>	<b>9</b>
<b>4</b>	<b>TTL-232R-5V and TTL-232R-3V3 Cables.....</b>	<b>10</b>
4.1	TTL-232R-5V, TTL-232R-3V3 Connector Pin Out and Mechanical details .....	10
4.2	TTL-232R-5V and TTL-232R-3V3 Cable Signal Descriptions ....	10
4.3	TTL-232R-5V and TTL-232R-3V3 Electrical Parameters.....	11
4.3.1	TTL-232R-5V Electrical Parameters .....	11
4.3.2	TTL-232R-3V3 Electrical Parameters .....	11
<b>5</b>	<b>TTL-232R-5V-AJ and TTL-232R-3V3-AJ .....</b>	<b>12</b>
5.1	TTL-232R-5V-AJ, TTL-232R-3V3-AJ Connector Pin Out and Mechanical details .....	12
5.2	TTL-232R-5V-AJ and TTL-232R-3V3-AJ Cable Signal Descriptions .....	13
5.3	TTL-232R-5V-AJ and TTL-232R-3V3-AJ Electrical Parameters	13
5.3.1	TTL-232R-5V-AJ Electrical Parameters.....	13
5.3.2	TTL-232R-3V3-AJ Electrical Parameters.....	13
<b>6</b>	<b>TTL-232R-5V-WE and TTL-232R-3V3-WE Cables .....</b>	<b>14</b>
6.1	TTL-232R-5V-WE, TTL-232R-3V3-WE Connections and Mechanical Details.....	14
6.2	TTL-232R-5V-WE and TTL-232R-3V3-WE Cable Signal Descriptions .....	14

---

<b>6.3</b>	<b>TTL-232R-5V-WE and TTL-232R-3V3-WE Electrical Parameters</b>	<b>15</b>
6.3.1	TTL-232R-5V-WE Electrical Parameters .....	15
6.3.2	TTL-232R-3V3-WE Electrical Parameters .....	15
<b>7</b>	<b>TTL-232R-3V3-2mm Cables.....</b>	<b>16</b>
7.1	TTL-232R-3V3-2mm Connector Pin Out and Mechanical details	16
7.2	TTL-232R-3V3-2mm Cable Signal Descriptions .....	17
7.3	TTL-232R-3V3-2mm Electrical Parameters .....	17
<b>8</b>	<b>Cable PCB Circuit Schematic.....</b>	<b>18</b>
<b>9</b>	<b>Contact Information.....</b>	<b>19</b>
<b>Appendix A - Cable EEPROM Configuration.....</b>		<b>20</b>
<b>Appendix B - References .....</b>		<b>21</b>
Document References .....		21
Acronyms and Abbreviations .....		21
<b>Appendix C - List of Figures and Tables .....</b>		<b>22</b>
List of Figures .....		22
List of Tables .....		22
<b>Appendix D - Revision History.....</b>		<b>23</b>

## 2 Typical Applications

- USB to Serial TTL Level Converter
- Upgrading Legacy Peripherals to USB
- Interface Microcontroller UART or I/O to USB
- Interface FPGA / PLD to USB
- Interface to FTDI VDRIVE2 or VMUSIC2 modules.
- Replace MAX232 type level shifters allowing for direct connection of products to PC via USB
- USB Instrumentation PC interface
- USB Industrial Control
- USB Software / Hardware Encryption Dongles

### 2.1 Driver Support

**Royalty free VIRTUAL COM PORT (VCP) and D2XX Direct Drivers** are available for the following Operating Systems (OS):

- Windows
- Linux
- Mac
- Android (J2xx / D2xx only)

See the following website link for the full driver support list including OS versions and legacy OS.

<https://ftdichip.com/drivers/>

**Virtual COM Port (VCP)** drivers cause the USB device to appear as an additional COM port available to the PC. Application software can access the USB device in the same way as it would access a standard COM port.

**D2XX Direct Drivers** allow direct access to the USB device through a DLL. Application software can access the USB device through a series of DLL function calls. The functions available are listed in the [D2XX Programmer's Guide](#) document which is available from the [Documents](#) section of our website.

Please also refer to the [Installation Guides](#) webpage for details on how to install the drivers.

## 2.2 Features

- TTL-232R Converter Cable provides a USB to TTL Serial interface with various end connectors.
- On board FT232RQ provides single chip USB to asynchronous serial data transfer interface.
- Entire USB protocol handled by the electronics in the cable USB.
- Connect directly to a microcontroller UART or I/O pins.
- UART interface support for 7 or 8 data bits, 1 or 2 stop bits and odd / even / mark / space / no parity.
- Fully assisted hardware (RTS#/CTS#) or X-On / X-Off software handshaking.
- Data transfer rates from 300 baud to 3 Mbaud at TTL levels.
- Internal EEPROM with user writeable area.
- 5V CMOS drive outputs and 5V safe TTL inputs makes the TTL-232R easy to interface to 5V MCU's.
- FTDI's royalty-free VCP allow for communication as a standard emulated COM port and D2XX 'direct' drivers provide DLL application programming interface.
- Support for FT232RQ FTDIChip-ID™ feature for improved security.
- +5V or +3.3V output allows external logic to be powered from the USB port.
- 6 way outputs provide Tx, Rx, RTS#, CTS#, VCC and GND (except Audio Jack which provides only TX, RX and GND).
- 8 way, keyed connector to support FTDI VDRIVE2 and VMUSIC2.
- 3 way Audio Jack connector provides Tx, Rx and GND.
- Low USB bandwidth consumption.
- UHCI / OHCI / EHCI host controller compatible.
- USB 2.0 Full Speed compatible.
- -40°C to +85°C operating temperature range.
- Cable length is 1.80m (6 feet).
- FCC, CE and UKCA compliant.
- Custom versions also available (subject to MOQ).



### 3 Features of FT232RQ applicable to TTL-232R Cables

The TTL-232R cables use FTDI's FT232RQ USB to serial IC device. This section summarises the key features of the FT232RQ which apply to the TTL-232R USB to serial TTL converter cables. For further details, and a full features and enhancements description consult the FT232RQ datasheet, this is available from [www.ftdichip.com](http://www.ftdichip.com).

**Internal EEPROM.** The internal EEPROM in each cable is used to store USB Vendor ID (VID), Product ID (PID), device serial number, product description string and various other USB configuration descriptors. Each cable is supplied with the internal EEPROM pre-programmed as described in section 9 Contact Information

A user area of the internal EEPROM is available to system designers to allow storing additional data. The internal EEPROM descriptors can be programmed in circuit, over USB without any additional voltage requirement. It can be programmed using the FTDI utility software called [FT\\_PROG](#), which can be downloaded from FTDI Utilities on the FTDI website (<https://ftdichip.com/>).

**Lower Operating and Suspend Current.** The FT232RQ has a low 15mA operating supply current and a very low USB suspend current of approximately 70µA. (Note that during suspend mode, the current drawn by application should not exceed 2.5mA to remain USB compliant).

**Low USB Bandwidth Consumption.** The USB interface of the FT232RQ, and therefore the TTL-232R cables has been designed to use as little as possible of the total USB bandwidth available from the USB host controller.

**High Output Drive Option.** The UART interface I/O pins on the TTL-232R cables (RXD, TXD, RTS#, and CTS#) can be configured to use the FT232RQ's high output drive option. This option allows the FT232RQ I/O pins to drive up to three times the standard signal drive level. This allows multiple devices to be driven, or devices that require a greater signal drive strength to be interfaced to the cables. This option is enabled in the internal EEPROM.

**UART Pin Signal Inversion.** The sense of each of the eight UART signals can be individually inverted by configuring options in the internal EEPROM. For example, CTS# (active low) can be changed to CTS (active high), or TXD can be changed to TXD#.

**FTDChip-ID™.** The FT232RQ includes the new FTDChip-ID™ security dongle feature. This FTDChip-ID™ feature allows a unique number to be burnt into each cable during manufacture. This number cannot be reprogrammed. This number is only readable over USB can be used to form the basis of a security dongle which can be used to protect any customer application software being copied. This allows the possibility of using the TTL-232R cables as a dongle for software licensing. Further to this, a renewable license scheme can be implemented based on the FTDChip-ID™ number when encrypted with other information. This encrypted number can be stored in the user area of the FT232RQ internal EEPROM, and can be decrypted, then compared with the protected FTDChip-ID™ to verify that a license is valid. Web based applications can be used to maintain product licensing this way. An application note, [AN232R-02](#), available from FTDI website (<https://ftdichip.com/>) describes this feature.

**Improved EMI Performance.** The TTL-232R cables are FCC, CE and UKCA certified.

**Extended Operating Temperature Range -** The TTL-232R cables are capable of operating over an extended temperature range of -40° to +85° C thus allowing them to be used in automotive or industrial applications.

## 4 TTL-232R-5V and TTL-232R-3V3 Cables

The TTL-232R-5V and TTL-232R-3V3 cables are both terminated by a 6 way, 0.1", Single-In-Line (SIL) connector. The difference between the two cables is that the TTL-232R-5V operates at +5V levels (signals and power supply) and the TTL-232R-3V3 operates at +3.3V levels (signals only, VCC= +5V).

### 4.1 TTL-232R-5V, TTL-232R-3V3 Connector Pin Out and Mechanical details

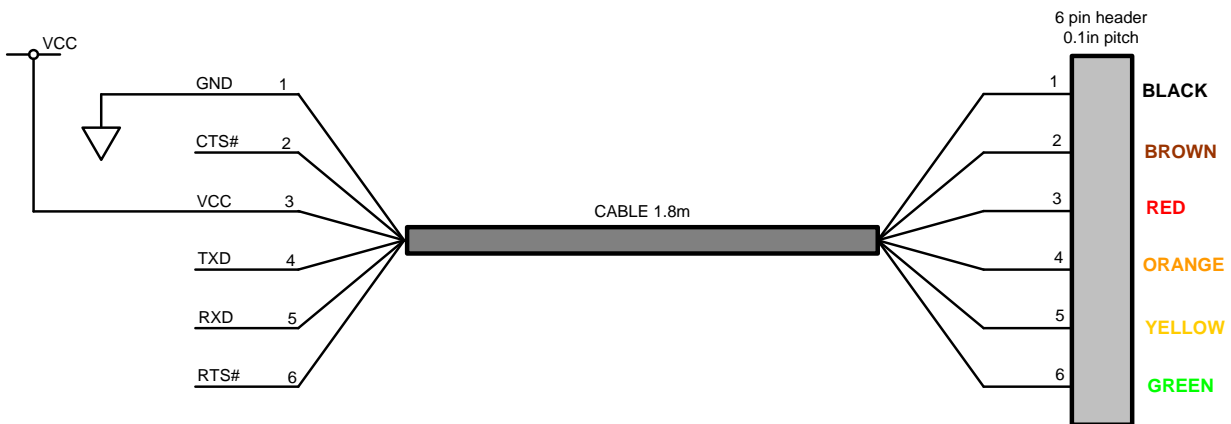

Figure 4.1 TTL-232R-5V and TTL-232R-3V3, 6 Way Header Pin Out

The mechanical details of the 6 way connector are shown in the following diagram

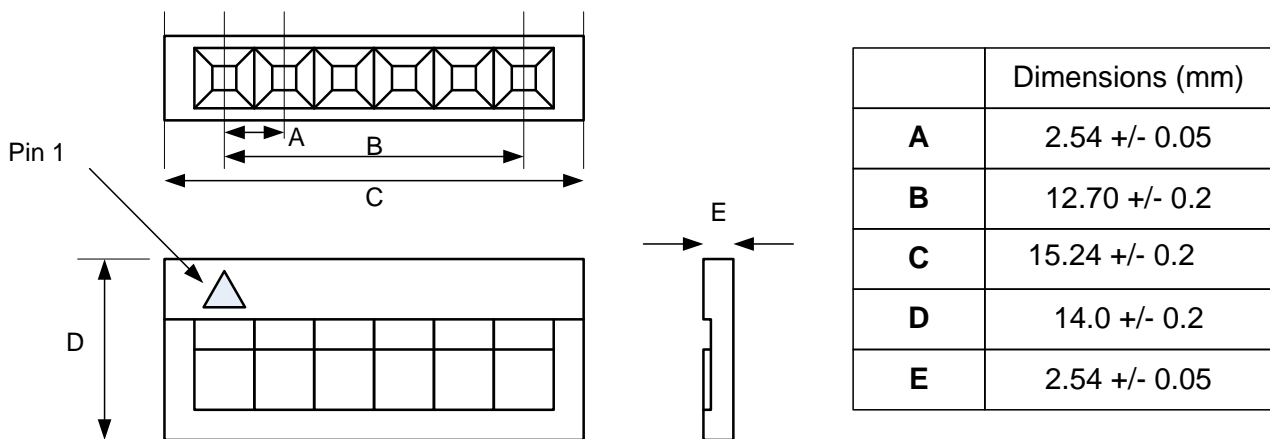

Figure 4.2 TTL-232R-5V TTL-232R-3V3, 6 Way Header Mechanical Details

### 4.2 TTL-232R-5V and TTL-232R-3V3 Cable Signal Descriptions

Header Pin Number	Name	Type	Colour	Description
1	GND	GND	Black	Device ground supply pin.
2	CTS#	Input	Brown	Clear to Send Control input / Handshake signal.
3	VCC	Output	Red	+5V output,
4	TXD	Output	Orange	Transmit Asynchronous Data output.
5	RXD	Input	Yellow	Receive Asynchronous Data input.
6	RTS#	Output	Green	Request To Send Control Output / Handshake signal.

Table 4.1 TTL-232R-5V and TTL-232R-3V3 Cable Signal Descriptions

### 4.3 TTL-232R-5V and TTL-232R-3V3 Electrical Parameters

#### 4.3.1 TTL-232R-5V Electrical Parameters

Parameter	Description	Minimum	Typical	Maximum	Units	Conditions
VCC	Output Power Voltage	4.25	5.0	5.25	V	Dependant on the USB port that the TTL-232R-5V is connected to
I <sub>o</sub>	Output Power Current	-	-	75	mA	Must be less than 2.5mA during suspend.
T	Operating Temperature Range	-40	-	+85	°C	

**Table 4.2 TTL-232R-5V I/O Operating Parameters**

Parameter	Description	Minimum	Typical	Maximum	Units	Conditions
V <sub>oh</sub>	Output Voltage High	3.2	4.1	4.9	V	I source = 2mA
V <sub>ol</sub>	Output Voltage Low	0.3	0.4	0.6	V	I sink = 2mA
V <sub>in</sub>	Input Switching Threshold	1.0	1.2	1.5	V	
V <sub>Hys</sub>	Input Switching Hysteresis	20	25	30	mV	

**Table 4.3 TTL-232R-5V I/O Pin Characteristics**

#### 4.3.2 TTL-232R-3V3 Electrical Parameters

Parameter	Description	Minimum	Typical	Maximum	Units	Conditions
VCC	Output Power Voltage	4.25	5.0	5.25	V	Dependant on the USB port that the TTL-232R-3V3 is connected to
I <sub>o</sub>	Output Power Current	-	-	75	mA	Must be less than 2.5mA during suspend.
T	Operating Temperature Range	-40	-	+85	°C	

**Table 4.4 TTL-232R-3V3 I/O Operating Parameters**

Parameter	Description	Minimum	Typical	Maximum	Units	Conditions
V <sub>oh</sub>	Output Voltage High	2.2	2.8	3.2	V	I source = 3mA
V <sub>ol</sub>	Output Voltage Low	0.3	0.4	0.6	V	I sink = 8mA
V <sub>in</sub>	Input Switching Threshold	1.0	1.2	1.5	V	
V <sub>Hys</sub>	Input Switching Hysteresis	20	25	30	mV	

**Table 4.5 TTL-232R-3V3 I/O Pin Characteristics**

## 5 TTL-232R-5V-AJ and TTL-232R-3V3-AJ

The TTL-232R-5V-AJ and TTL-232R-3V3-AJ cables are both terminated by a standard 3.5mm Audio Jack (AJ) connector. The difference between the two cables is that the TTL-232R-5V-AJ operates at +5V levels (signals and power supply) and the TTL-232R-3V3-AJ operates at +3.3V levels (signals and power supply). On these cables the VCC power is not transferred.

### 5.1 TTL-232R-5V-AJ, TTL-232R-3V3-AJ Connector Pin Out and Mechanical details

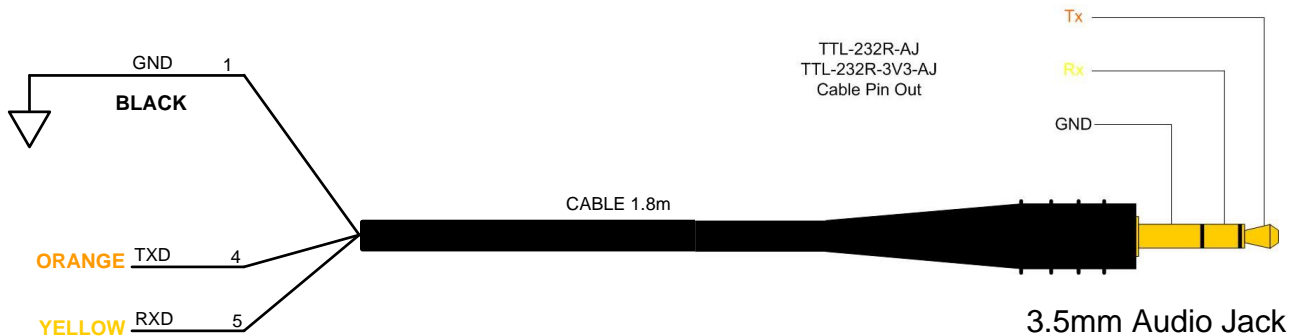

**Figure 5.1 TTL-232R-5V and TTL-232R-3V3, -AJ Pin Out**

The mechanical details of the Audio Jack connector are shown in the following **Figure 5.2**.

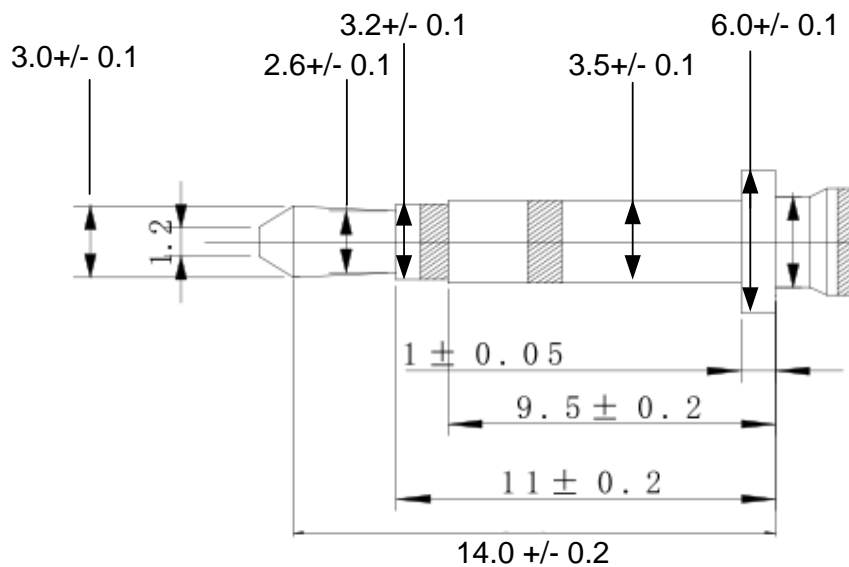

Dimensions in mm

**Figure 5.2 TTL-232R-5V-AJ and TTL-232R-3V3-AJ Audio Jack Mechanical Details**

## 5.2 TTL-232R-5V-AJ and TTL-232R-3V3-AJ Cable Signal Descriptions

Header Pin Number	Name	Type	Description
TIP	TXD	Output	Transmit Asynchronous Data output.
RING	RXD	Input	Receive Asynchronous Data input.
SLEEVE	GND	GND	GND

Table 5.1 TTL-232R-5V-AJ and TTL-232R-3V3-AJ Cable Signal Descriptions

## 5.3 TTL-232R-5V-AJ and TTL-232R-3V3-AJ Electrical Parameters

### 5.3.1 TTL-232R-5V-AJ Electrical Parameters

Parameter	Description	Minimum	Typical	Maximum	Units	Conditions
$I_o$	Output Power Current	-		75	mA	Must be less than 2.5mA during suspend.
T	Operating Temperature Range	-40		+85	°C	

Table 5.2 TTL-232R-5V-AJ I/O Operating Parameters

Parameter	Description	Minimum	Typical	Maximum	Units	Conditions
Voh	Output Voltage High	3.2	4.1	4.9	V	I source = 6mA
Vol	Output Voltage Low	0.3	0.4	0.6	V	I sink = 6mA
Vin	Input Switching Threshold	1.0	1.2	1.5	V	
VHys	Input Switching Hysteresis	20	25	30	mV	

Table 5.3 TTL-232R-5V-AJ I/O Pin Characteristics

### 5.3.2 TTL-232R-3V3-AJ Electrical Parameters

Parameter	Description	Minimum	Typical	Maximum	Units	Conditions
$I_o$	Output Power Current	-		75	mA	Must be less than 2.5mA during suspend.
T	Operating Temperature Range	-40		+85	°C	

Table 5.4 TTL-232R-3V3-AJ I/O Operating Parameters

Parameter	Description	Minimum	Typical	Maximum	Units	Conditions
Voh	Output Voltage High	2.2	2.8	3.2	V	I source = 3mA
Vol	Output Voltage Low	0.3	0.4	0.6	V	I sink = 8mA
Vin	Input Switching Threshold	1.0	1.2	1.5	V	
VHys	Input Switching Hysteresis	20	25	30	mV	

Table 5.5 TTL-232R-3V3-AJ I/O Pin Characteristics

## 6 TTL-232R-5V-WE and TTL-232R-3V3-WE Cables

The TTL-232R-5V-WE and TTL-232R-3V3-WE cables are both un-terminated; they are bare and tinned wires. The difference between the two cables is that the TTL-232R-5V-WE operates at +5V levels (signals and power supply) and the TTL-232R-3V3-WE operates at +3.3V levels (signals only, VCC=+5V).

### 6.1 TTL-232R-5V-WE, TTL-232R-3V3-WE Connections and Mechanical Details

The following Figure 6.1 shows the cable signals and the wire colours for these signals on the TTL-232R-5V-WE and TTL-232R-3V3-WE cables.

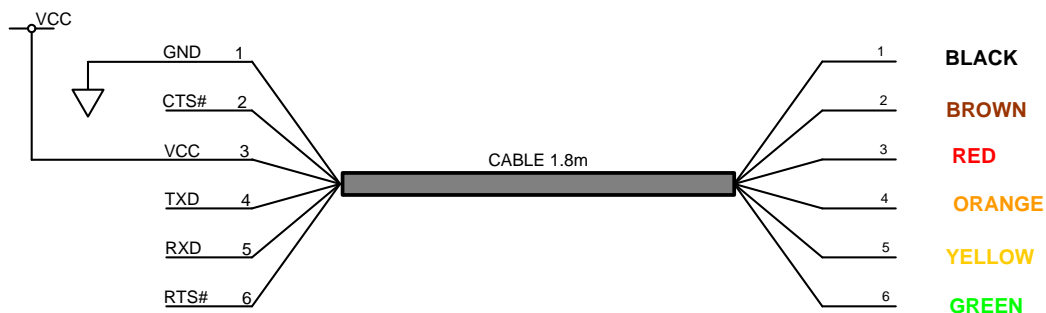

Figure 6.1 TTL-232R-5V-WE and TTL-232R-3V3-WE Connections

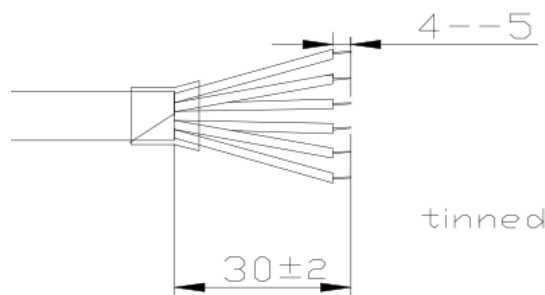

Figure 6.2 TTL-232R-5V-WE and TTL-232R-3V3-WE Mechanical Details (dimensions in mm)

### 6.2 TTL-232R-5V-WE and TTL-232R-3V3-WE Cable Signal Descriptions

Colour	Name	Type	Description
Black	GND	GND	Device ground supply pin.
Brown	CTS#	Input	Clear to Send Control input / Handshake signal.
Red	VCC	Output	+5V output
Orange	TXD	Output	Transmit Asynchronous Data output.
Yellow	RXD	Input	Receive Asynchronous Data input.
Green	RTS#	Output	Request To Send Control Output / Handshake signal.

Table 6.1 TTL-232R-5V-WE and TTL-232R-3V3-WE Cable Signal Descriptions

## 6.3 TTL-232R-5V-WE and TTL-232R-3V3-WE Electrical Parameters

### 6.3.1 TTL-232R-5V-WE Electrical Parameters

Parameter	Description	Minimum	Typical	Maximum	Units	Conditions
VCC	Output Power Voltage	4.25	5.0	5.25	V	Dependant on the USB port that the TTL-232R-5V-WE is connected to
I <sub>o</sub>	Output Power Current	-		75	mA	Must be less than 2.5mA during suspend.
T	Operating Temperature Range	-40		+85	°C	

Table 6.2 TTL-232R-5V-WE I/O Operating Parameters

Parameter	Description	Minimum	Typical	Maximum	Units	Conditions
V <sub>oh</sub>	Output Voltage High	3.2	4.1	4.9	V	I source = 6mA
V <sub>ol</sub>	Output Voltage Low	0.3	0.4	0.6	V	I sink = 6mA
V <sub>in</sub>	Input Switching Threshold	1.0	1.2	1.5	V	
V <sub>Hys</sub>	Input Switching Hysteresis	20	25	30	mV	

Table 6.3 TTL-232R-5V-WE I/O Pin Characteristics

### 6.3.2 TTL-232R-3V3-WE Electrical Parameters

Parameter	Description	Minimum	Typical	Maximum	Units	Conditions
VCC	Output Power Voltage	4.25	5.0	5.25	V	Dependant on the USB port that the TTL-232R-3V3-WE is connected to
I <sub>o</sub>	Output Power Current	-		75	mA	Must be less than 2.5mA during suspend.
T	Operating Temperature Range	-40		+85	°C	

Table 6.4 TTL-232R-3V3-WE I/O Operating Parameters

Parameter	Description	Minimum	Typical	Maximum	Units	Conditions
V <sub>oh</sub>	Output Voltage High	2.2	2.8	3.2	V	I source = 3mA
V <sub>ol</sub>	Output Voltage Low	0.3	0.4	0.6	V	I sink = 8mA
V <sub>in</sub>	Input Switching Threshold	1.0	1.2	1.5	V	
V <sub>Hys</sub>	Input Switching Hysteresis	20	25	30	mV	

Table 6.5 TTL-232R-3V3-WE I/O Pin Characteristics

## 7 TTL-232R-3V3-2mm Cables

The TTL-232R-3V3-2mm cable is terminated by an 8 way, 2mm pitch, Single-In-Line (SIL) keyed connector. The TTL-232R-3V3-2mm operates at +3.3V levels (signals and power supply). These cables are primarily intended for interfacing the FTDI VDRIVE2 and VMUSIC2 modules.

Note that when connected to VDRIVE2 or VMUSIC2 module, the TTL-232R-3V3-2mm cable 8-way connector pin 1 connects to pin 8 of the module, and pin 8 of the cable connects to pin 1 of the cable.

### 7.1 TTL-232R-3V3-2mm Connector Pin Out and Mechanical details

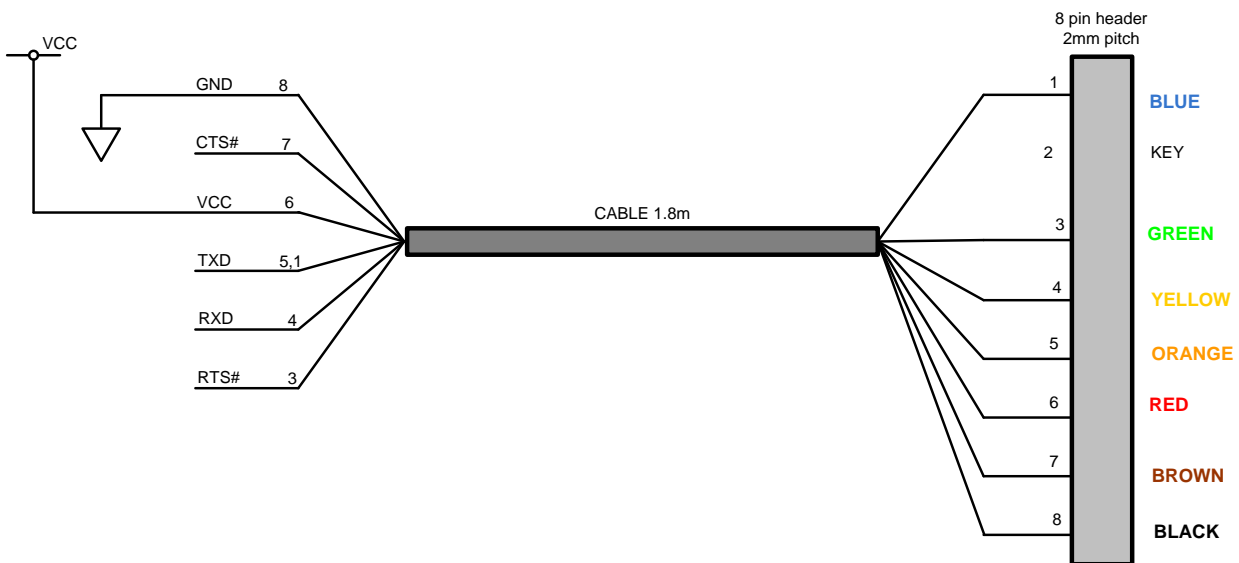

Figure 7.1 TTL-232R-3V3-2mm, 8 Way Header Pin Out

The mechanical details of the 2mm pitch 8 way, keyed, connector are shown in the following diagram

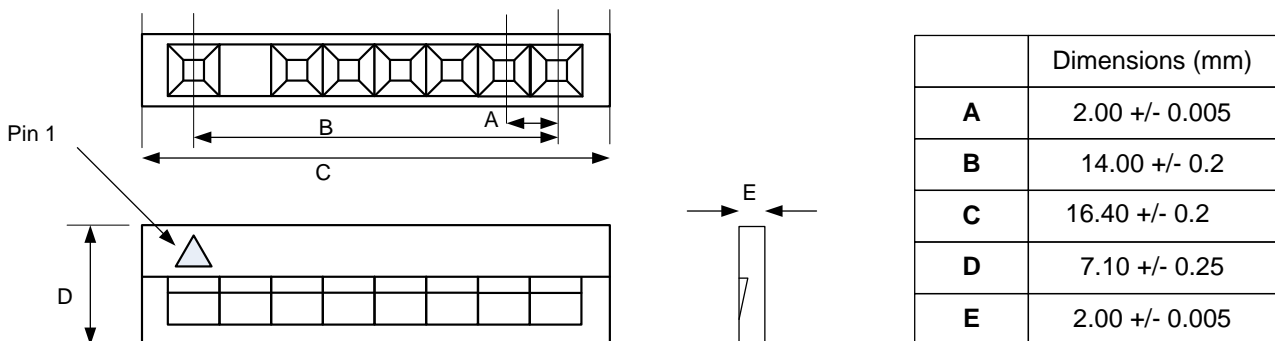

Figure 7.2 TTL-232R-3V3-2mm, 2mm pitch, Keyed, 8 way Header Mechanical Details



## 7.2 TTL-232R-3V3-2mm Cable Signal Descriptions

Header Pin Number	Name	Type	Colour	Description
1	RI#	Output	Blue	Ring Indicator Control Input. When remote wake up is enabled taking RI# low (20ms active low pulse) can be used to resume the VMUSIC2 or VDRIVE2 host controller from suspend. Connected to TXD.
2	KEY	KEY	KEY	This connection is keyed to connect to the VRDIVE2 or the VMUSIC2 modules
3	RTS#	Output	Green	Request To Send Control Output / Handshake signal.
4	RXD	Input	Yellow	Receive Asynchronous Data input.
5	TXD	Output	Orange	Transmit Asynchronous Data output.
6	VCC	Output	Red	+5V output,
7	CTS#	Input	Brown	Clear to Send Control input / Handshake signal.
8	GND	GND	Black	Device ground supply pin.

Table 7.1 TTL-232R-3V3-2mm Cable Signal Descriptions

## 7.3 TTL-232R-3V3-2mm Electrical Parameters

Parameter	Description	Minimum	Typical	Maximum	Units	Conditions
VCC	Output Power Voltage	4.25	5.0	5.25	V	Dependant on the USB port that the TTL-232R-3V3-2mm is connected to
I <sub>o</sub>	Output Power Current	-		75	mA	Must be less than 2.5mA during suspend.
T	Operating Temperature Range	-40		+85	°C	

Table 7.2 TTL-232R-3V3-2mm I/O Operating Parameters

Parameter	Description	Minimum	Typical	Maximum	Units	Conditions
V <sub>oh</sub>	Output Voltage High	2.2	2.8	3.2	V	I source = 3mA
V <sub>ol</sub>	Output Voltage Low	0.3	0.4	0.6	V	I sink = 8mA
V <sub>in</sub>	Input Switching Threshold	1.0	1.2	1.5	V	
V <sub>Hys</sub>	Input Switching Hysteresis	20	25	30	mV	

Table 7.3 TTL-232R-3V3-2mm I/O Pin Characteristics

## 8 Cable PCB Circuit Schematic

The circuit schematic for the small internal electronic circuit board, utilising the FTDI FT232RQ, which is encapsulated into the USB connector end of the cable, is shown in Figure 8.1.

Customised versions of these cables are also available. Users interested in customised versions of these cables should contact FTDI sales ([sales1@ftdichip.com](mailto:sales1@ftdichip.com)).

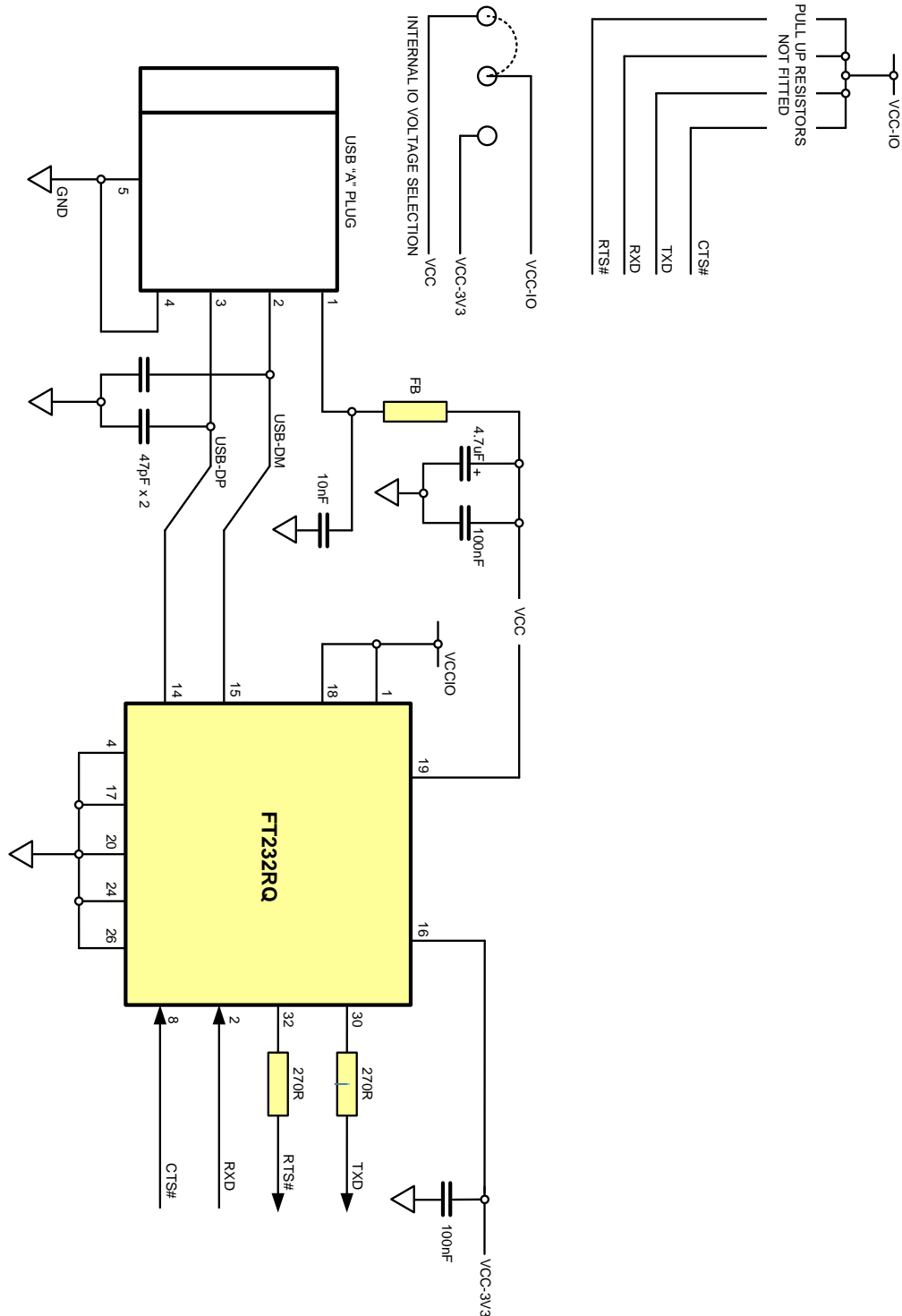

Figure 8.1 Circuit Schematic of PCB Used in the TTL to USB Serial Converter Cables

## 9 Contact Information

### Head Office – Glasgow, UK

Future Technology Devices International Limited  
Unit 1, 2 Seaward Place, Centurion Business Park  
Glasgow G41 1HH  
United Kingdom  
Tel: +44 (0) 141 429 2777  
Fax: +44 (0) 141 429 2758

E-mail (Sales) [sales1@ftdichip.com](mailto:sales1@ftdichip.com)  
E-mail (Support) [support1@ftdichip.com](mailto:support1@ftdichip.com)  
E-mail (General Enquiries) [admin1@ftdichip.com](mailto:admin1@ftdichip.com)

### Branch Office – Tigard, Oregon, USA

Future Technology Devices International Limited (USA)  
7130 SW Fir Loop  
Tigard, OR 97223-8160  
USA  
Tel: +1 (503) 547 0988  
Fax: +1 (503) 547 0987

E-mail (Sales) [us.sales@ftdichip.com](mailto:us.sales@ftdichip.com)  
E-mail (Support) [us.support@ftdichip.com](mailto:us.support@ftdichip.com)  
E-mail (General Enquiries) [us.admin@ftdichip.com](mailto:us.admin@ftdichip.com)

### Branch Office – Taipei, Taiwan

Future Technology Devices International Limited (Taiwan)  
2F, No. 516, Sec. 1, NeiHu Road  
Taipei 114  
Taiwan, R.O.C.  
Tel: +886 (0) 2 8797 1330  
Fax: +886 (0) 2 8751 3576

E-mail (Sales) [tw.sales1@ftdichip.com](mailto:tw.sales1@ftdichip.com)  
E-mail (Support) [tw.support1@ftdichip.com](mailto:tw.support1@ftdichip.com)  
E-mail (General Enquiries) [tw.admin1@ftdichip.com](mailto:tw.admin1@ftdichip.com)

### Branch Office – Shanghai, China

Future Technology Devices International Limited (China)  
Room 1103, No. 666 West Huaihai Road,  
Shanghai, 200052  
China  
Tel: +86 21 62351596  
Fax: +86 21 62351595

E-mail (Sales) [cn.sales@ftdichip.com](mailto:cn.sales@ftdichip.com)  
E-mail (Support) [cn.support@ftdichip.com](mailto:cn.support@ftdichip.com)  
E-mail (General Enquiries) [cn.admin@ftdichip.com](mailto:cn.admin@ftdichip.com)

### Web Site

<https://ftdichip.com/>

### Distributor and Sales Representatives

Please visit the Sales Network page of the [FTDI Web site](#) for the contact details of our distributor(s) and sales representative(s) in your country.

System and equipment manufacturers and designers are responsible to ensure that their systems, and any Future Technology Devices International Ltd (FTDI) devices incorporated in their systems, meet all applicable safety, regulatory and system-level performance requirements. All application-related information in this document (including application descriptions, suggested FTDI devices and other materials) is provided for reference only. While FTDI has taken care to assure it is accurate, this information is subject to customer confirmation, and FTDI disclaims all liability for system designs and for any applications assistance provided by FTDI. Use of FTDI devices in life support and/or safety applications is entirely at the user's risk, and the user agrees to defend, indemnify and hold harmless FTDI from any and all damages, claims, suits or expense resulting from such use. This document is subject to change without notice. No freedom to use patents or other intellectual property rights is implied by the publication of this document. Neither the whole nor any part of the information contained in, or the product described in this document, may be adapted or reproduced in any material or electronic form without the prior written consent of the copyright holder. Future Technology Devices International Ltd, Unit 1, 2 Seaward Place, Centurion Business Park,

## Appendix A - Cable EEPROM Configuration

Each TTL-232R cable is controlled by the FTDI FT232RQ IC. This FT232RQ device contains an EEPROM which contains the USB configuration descriptors for that device. When the cable is plugged into a PC or a USB reset is performed, the PC will read these descriptors. The default values stored into the internal EEPROM are defined in the table given below.

Parameter	Value	Notes
USB Vendor ID (VID)	0403h	FTDI default VID (hex)
USB Product ID (PID)	6001h	FTDI default PID (hex)
Serial Number Enabled?	Yes	
Serial Number	See Note	A unique serial number is generated and programmed into the EEPROM during device final test.
Pull down I/O Pins in USB Suspend	Disabled	Enabling this option will make the device pull down on the UART interface lines when the power is shut off (PWREN# is high).
Manufacturer Name	FTDI	
Product Description	See note	Product description depends on the cable. The following lists the Product description for each different cable. TTL-232R-5V TTL-232R-3V3 TTL-232R-5V-AJ TTL-232R-AJ-3V3 TTL-232R-5V-WE TTL-232R-3V3-WE TTL-232R-3V3-2mm = USB <-> Serial Cable
Max Bus Power Current	90mA	
Power Source	Bus Powered	
Device Type	FT232R	
USB Version	0200	Returns USB 2.0 device description to the host. Note: The device is a USB 2.0 Full Speed device (12Mb/s) as opposed to a USB 2.0 High Speed device (480Mb/s).
Remote Wake Up	Disabled	
High Current I/Os	Enabled	Enables the high drive level on the UART and CBUS I/O pins.
Load VCP Driver	Enabled	Makes the device load the VCP driver interface for the device.
Invert TXD	Disabled	Signal on this pin becomes TXD# if enable.
Invert RXD	Disabled	Signal on this pin becomes RXD# if enable.
Invert RTS#	Disabled	Signal on this pin becomes RTS if enable.
Invert CTS#	Disabled	Signal on this pin becomes CTS if enable.

### Default Internal EEPROM Configuration

The internal EEPROM in the cable can be re-programmed over USB using the utility program [FT\\_PROG](#). FT\_PROG can be downloaded from the [www.ftdichip.com](http://www.ftdichip.com). Version 2.8a or later is required for the FT232RQ chip. Users who do not have their own USB Vendor ID but who would like to use a unique Product ID in their design can apply to FTDI for a free block of unique PIDs. Contact FTDI support for this service.

## Appendix B - References

### Document References

[FT232RQ USB UART IC Datasheet](#)

[D2XX Programmer's Guide](#)

[Installation Guides](#)

[FTDIChip-ID Projects](#)

[FT\\_PROG](#)

### Acronyms and Abbreviations

Terms	Description
DLL	Dynamic Link Library
EHCI	Enhanced Host Controller Interface
EEPROM	Electrically Erasable Programmable Read Only Memory
FPGA	Field Programmable Gate Array
IC	Integrated Circuit
MCU	Microcontroller Unit
RoHS	Restriction of Hazardous Substance
SIL	Single In Line
OHCI	Open Host Controller Interface
OS	Operating System
PLD	Programmable Logic Device
TTL	Transistor-Transistor Logic
USB	Universal Serial Bus
UART	Universal Asynchronous Receiver/Transmitter
UHCI	Universal Host Controller Interface

## Appendix C - List of Figures and Tables

### List of Figures

Figure 1.1 Using the TTL-232R Cable .....	2
Figure 4.1 TTL-232R-5V and TTL-232R-3V3, 6 Way Header Pin Out .....	10
Figure 4.2 TTL-232R-5V TTL-232R-3V3, 6 Way Header Mechanical Details .....	10
Figure 5.1 TTL-232R-5V and TTL-232R-3V3, -AJ Pin Out.....	12
Figure 5.2 TTL-232R-5V-AJ and TTL-232R-3V3-AJ Audio Jack Mechanical Details .....	12
Figure 6.1 TTL-232R-5V-WE and TTL-232R-3V3-WE Connections.....	14
Figure 6.2 TTL-232R-5V-WE and TTL-232R-3V3-WE Mechanical Details (dimensions in mm) .....	14
Figure 7.1 TTL-232R-3V3-2mm, 8 Way Header Pin Out .....	16
Figure 7.2 TTL-232R-3V3-2mm, 2mm pitch, Keyed, 8 way Header Mechanical Details.....	16
Figure 8.1 Circuit Schematic of PCB Used in the TTL to USB Serial Converter Cables .....	18

### List of Tables

Table 1.1 TTL-232R Cables Descriptions and Part Numbers .....	3
Table 4.1 TTL-232R-5V and TTL-232R-3V3 Cable Signal Descriptions .....	10
Table 4.2 TTL-232R-5V I/O Operating Parameters .....	11
Table 4.3 TTL-232R-5V I/O Pin Characteristics .....	11
Table 4.4 TTL-232R-3V3 I/O Operating Parameters.....	11
Table 4.5 TTL-232R-3V3 I/O Pin Characteristics.....	11
Table 5.1 TTL-232R-5V-AJ and TTL-232R-3V3-AJ Cable Signal Descriptions .....	13
Table 5.2 TTL-232R-5V-AJ I/O Operating Parameters .....	13
Table 5.3 TTL-232R-5V-AJ I/O Pin Characteristics .....	13
Table 5.4 TTL-232R-3V3-AJ I/O Operating Parameters .....	13
Table 5.5 TTL-232R-3V3-AJ I/O Pin Characteristics .....	13
Table 6.1 TTL-232R-5V-WE and TTL-232R-3V3-WE Cable Signal Descriptions .....	14
Table 6.2 TTL-232R-5V-WE I/O Operating Parameters.....	15
Table 6.3 TTL-232R-5V-WE I/O Pin Characteristics.....	15
Table 6.4 TTL-232R-3V3-WE I/O Operating Parameters .....	15
Table 6.5 TTL-232R-3V3-WE I/O Pin Characteristics.....	15
Table 7.1 TTL-232R-3V3-2mm Cable Signal Descriptions .....	17
Table 7.2 TTL-232R-3V3-2mm I/O Operating Parameters .....	17
Table 7.3 TTL-232R-3V3-2mm I/O Pin Characteristics .....	17

## Appendix D - Revision History

Document Title: TTL-232R TTL to USB Serial Converter Range of Cables Datasheet  
Document Reference No.: FT\_000054  
Clearance No.: FTDI# 53  
Product Page: [Cables](#)  
Document Feedback: [Send Feedback](#)

Revision	Changes	Date
Version 1.00	Full datasheet released	2006-05-01
Version 2.00	Consolidated all TTL-232R variants into one datasheet. Changed part numbers for +5V cables.	2008-07-10
Version 2.01	Corrected Table 6.1, RED wire VCC description	2008-09-01
Version 2.02	Corrected Table 4.3, I source and I sink values. Added section 1.3 USB Compliant Logo. Updated contact details. Replaced reference MProg with FT_Prog	2010-09-02
Version 2.03	Corrected title of fig 5.1. Removed colour column from table 5.1 – cables are encapsulated and not visible.	2011-06-02
Version 2.04	Corrected Table 5.1. Further document template changes made.	2019-02-14
Version 2.05	Added UKCA, updated part number to FT232RQ. Updated driver support and links.	12-07-2023